

Midterm # 2

- 1) A circuit contains a $1\text{ k}\Omega$ resistor and a 500 mH inductor in series. Initially the circuit is connected to a 1 kHz AC source with $100\text{ V}_{\text{rms}}$ amplitude.
- a) What is the amplitude of the AC current in the circuit when the switch S_1 is closed?
 - b) At the instant t_0 when the current in the circuit is maximum, the AC source is disconnected (S_1 is opened) and switch B is closed. Write down an expression for the current in this case.
 - c) What is the total energy dissipated in the resistor after the switch is closed?

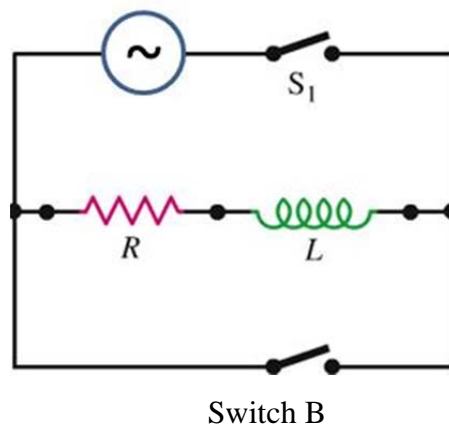

2) A beam of light enters a glass prism ($n = 1.65$) as shown in figure, normally to the AB face. When the prism is surrounded by air ($n = 1$) the beam is totally internally reflected at face AC. When the prism is immersed in a clear liquid, the beam exits the prism through face AC.

a) What minimum value of the index of refraction of the liquid permits the beam to exit?

b) If the beam of light enters the prism at 30 degrees as shown in the figure, what is the minimum value of the index of refraction of the liquid that permits the beam to exit in this case?

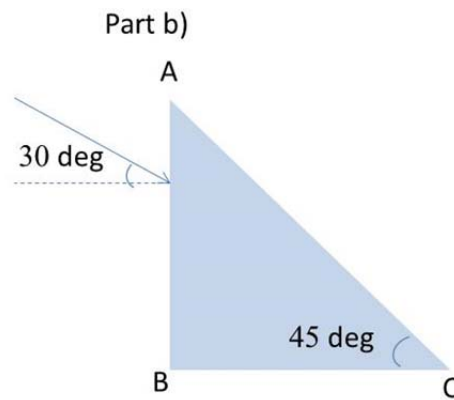
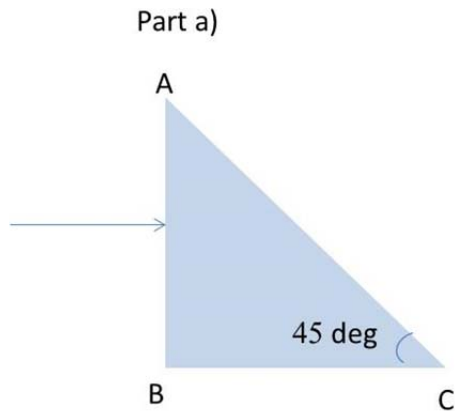

- 3) The electric field in an electromagnetic wave at a distance $d = 100$ mm from a radio-emitting antenna has a maximum amplitude of $E_0 = 6 \cdot 10^5$ V/m.
- a) What is the intensity?
 - b) Assume that the antenna emits a spherical wave front propagating in all directions, what is the intensity at 500 m from the antenna?
 - c) What is the maximum magnetic field value at 500 m from the antenna?