

Name: _____

Student ID #: _____

Signature: _____

April 30, 2021

Physics 1C Midterm #2

- You have 60 minutes to complete this exam, and it is recommended to finish your work in 50 minutes so that you have 10 minutes to upload it to GradeScope. THERE IS A STRICT LATE EXAM POLICY: -10% IMMEDIATELY PLUS -10% EVERY ADDITIONAL 5 MINUTES.
- Remote exam rules:
 - Keep your cameras on during the exam, including the period in which you submit your answers to GradeScope. You may step away during the first 5 minutes of the exam period if you are printing out the exam, and, if necessary, to scan answers during the last 5 minutes, but send a note to the chat window to explain that is what you are doing.
 - The exam is open notes, open book, you can use any type of calculator, but you must not communicate with classmates or other people during the exam.
 - Please check your chat window occasionally in case there are needed clarifications. You can ask clarifying questions of the professor using the chat window, but be aware that he may be very busy with other students, and it is possible that your question gets overlooked so you might need to repeat it.
- You MUST sign and date the 2nd page entitled “Academic Integrity – A Bruin’s Code of Conduct” in order to receive credit for your work.
-
- Remember to write down each step of your calculation, and explain your answers fully.

Score :

I. _____/10 points

II. _____/10 points

III. _____/10 points

Total _____/30 points

Academic Integrity - A Bruin's Code of Conduct:

UCLA is a community of scholars committed to the values of integrity. In this community, all members including faculty, staff, and students alike are responsible for maintaining the highest standards of academic honesty and quality of academic work. As a student and member of the UCLA community, you are expected to demonstrate integrity in all of your academic endeavors. When accusations of academic dishonesty occur, the Office of the Dean of Students investigates and adjudicates suspected violations of this student code. Unacceptable behavior include cheating, fabrication or falsification, plagiarism, multiple submissions without instructor permission, using unauthorized study aids, facilitating academic misconduct, coercion regarding grading or evaluation of coursework, or collaboration not authorized by the instructor. Please review our campus' policy on academic integrity in the UCLA Student Conduct Code: <https://deanofstudents.ucla.edu/individual-student-code>

If you engage in these types of unacceptable behaviors in our course, then you will receive a zero as your score for that assignment. If you are caught cheating on an exam, then you will receive a score of zero for the entire exam. These allegations will be referred to the Office of the Dean of Students and can lead to formal disciplinary proceedings. Being found responsible for violations of academic integrity can result in disciplinary actions such as the loss of course credit for an entire term, suspension for several terms, or dismissal from the University. Such negative marks on your academic record may become a major obstacle to admission to graduate, medical, or professional school.

We cannot make exceptions to our campus' policy on academic integrity, and as we hopefully have communicated effectively here, penalties for violations of this policy are harsh. Please do not believe it if you hear that "everyone does it". The truth is, you usually don't hear about imposed disciplinary actions because they are kept confidential. So our advice, just don't do it! Let's embrace what it means to be a true Bruin and together be committed to the values of integrity.

By submitting my assignments and exams for grading in this course, I acknowledge the above-mentioned terms of the UCLA Student Code of Conduct, declare that my work will be solely my own, and that I will not communicate with anyone other than the instructor and proctors in any way during the exams.

Signature

Date

Print Name

UID

I (10 points) A cylindrical solenoid coil is shown in cross-section below. It has been wound with wire exactly as shown.

- a) (1 pt) Determine your individual seed value C for subsequent problems in the following way: C is the last non-zero of your student ID number. [For example, if your student ID is 0037600, your seed value will be $C = 6$]

My individual seed value $C =$ _____

- b) (4 pts) Sketch at least 4 of the magnetic field lines created by current that passes through the wires in the directions indicated.
- c) (5 pts) What is the approximate magnetic field near the center of the coil that is produced by a current of C Amps through the wire? [Assume for this part that infinite solenoid is an acceptable approximation.]

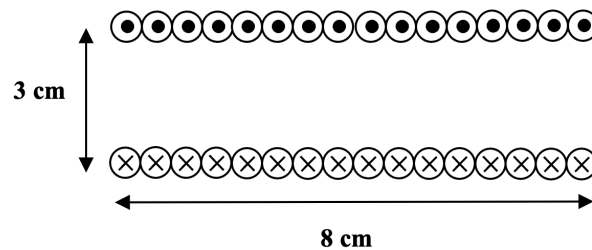

Additional paper for answer to problem I

II (10 points): The central part of a simple motor is made from a square coil of wire containing N loops, with each side having length ℓ . The coil rotates at constant frequency f about the x -axis in a constant magnetic field B aligned with the y -axis, and at time $t = 0$ the loops of the coil are in the $x - y$ plane.

- a) (2 pts) In terms of the variables above, what is the flux through the coil at time $t = 0$?
- b) (3 pts) What is the maximum flux through the coil?
- c) (3 pts) Write down an equation for the induced voltage on the coil.
- d) (2 pts) If each side of the coil has length $\ell = C$ cm (your seed value C calculated in problem I), the coil consists of $N=1000$ turns of wire, and the magnetic field strength is 0.5 Tesla, solve for the number revolutions per second needed for the coil to generate a maximum voltage of 170 v.

Additional paper for answer to problem II

III (10 points): Consider the circuit diagram shown below. Before time $t = 0$, there was no current flowing through the system and charge on the capacitor was zero. At time $t = 0$, the switch S is closed. This creates current i_1 through the branch with the inductor, and current i_2 through the branch with the capacitor. Take i_1 and i_2 to be positive if they pass through the resistors R_1 and R_2 from left to right.

- (4 points) Without solving, write down two circuit equations that will be needed to figure out the currents i_1 and i_2 in terms of the variables shown in the diagram.
- (3 points) Find $i_1(t)$
- (3 points) Find the current passing through the battery as a function of time.

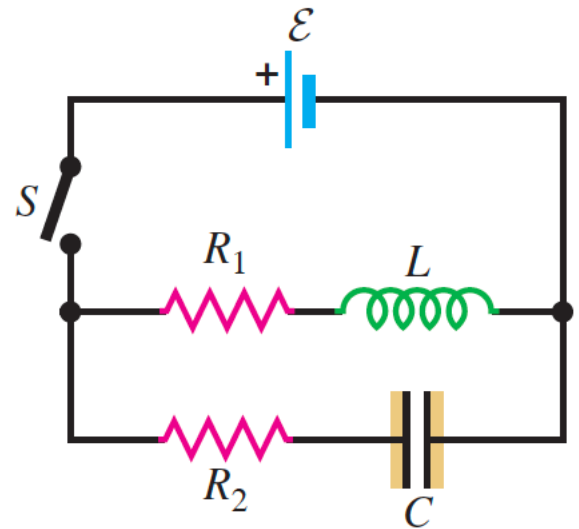

Additional paper for answer to problem III