

LAST Name: Patel

FIRST Name: Deven

University ID: 104766 465

Discussion Section: Friday 12-1

PHYSICS 1C: Electrodynamics, Optics, and Special Relativity

Fall 2017, Lecture Series 2

Midterm 1 Thursday 26th October

Version D

Time allowed: 50 minutes

Answer all questions

Calculators are permitted in this exam

The numbers in the margin indicate the weight that the examiners expect to assign to each part of the question

Do NOT turn over until told that you may do so.

Question	Points
1	5 / 6
2	6 / 6
3	12 / 12
4	25 / 25
5	23 / 25
6	9 / 26

Section A

1. The figure below shows a conducting metallic strip extending in the x direction (with density J_x) and a magnetic field in y direction (with strength B_y). Also shown is a single, negatively charged, conduction electron.

- Add arrows to the diagram to indicate the drift velocity of the electron \vec{v}_D and the magnetic force it experiences \vec{F}_B
- Add '+' and '-' signs to the diagram to indicate the resulting build-up of charge
- Add an arrow \vec{E} to show the electrostatic field that is developed by the charge separation.
- Add an arrow \vec{F}_E to show the electric force experienced by the electron.

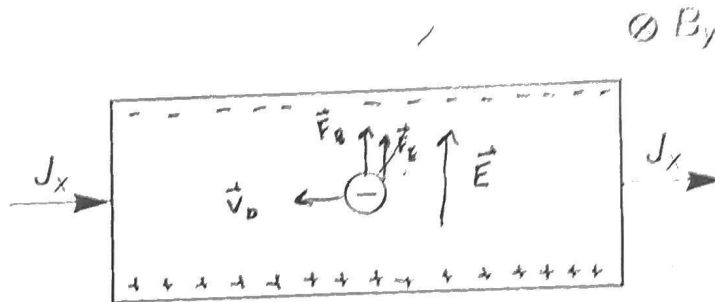

$$F = q\vec{v} \times \vec{B}$$

$$= qv(-\hat{y})B(\hat{z})$$

$$= qv(-\hat{y})B(\hat{z}) \rightarrow qvB(-\hat{x})$$

so \vec{F}_B is to the left

2. The figure below shows a diamagnetic material (on the left) close to the north pole of a permanent magnet (on the right). Indicate the direction of the dipoles in the diamagnetic material, and add an arrow to show the direction of the resulting force.

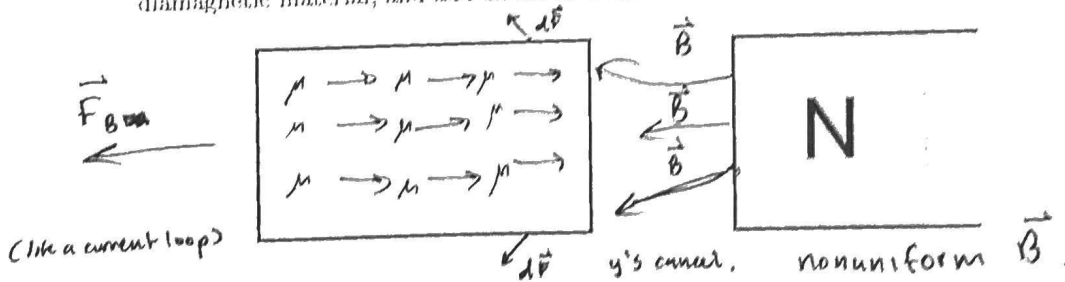

Are the dipoles above pre-existing or induced?

induced

What would be a suitable value of the relative permeability K_m for a diamagnetic material?

~~bet~~ $0 < K_m < 1$ $x < 1$
 so maybe $K_m \approx .5$

3. The movement of an aeroplane through the Earth's magnetic field may generate a motional emf between the tips of its wings. By modelling the region between the wings as a conducting rod of length $L = 50$ m travelling at a speed of $v = 100$ m/s, estimate the magnitude of the motional emf. You may assume that the Earth's magnetic field has strength $B = 1 \times 10^{-4}$ T and points vertically downwards, and that the plane is flying horizontally with respect to the magnetic field, as shown in the figure below. [12]

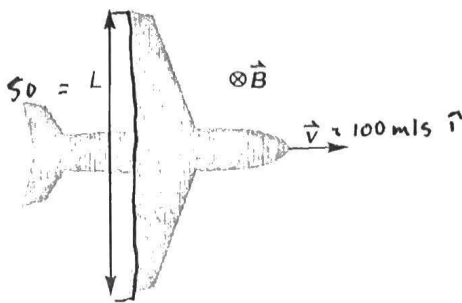

$$\begin{aligned}
 \mathcal{E} &= \oint (\mathbf{v} \times \mathbf{B}) \cdot d\mathbf{l} \\
 &= \int (\mathbf{v} \times \mathbf{B}) \cdot d\mathbf{l} \\
 &= vBL \cos(0) \\
 &= vBL \\
 &= (100 \text{ m/s})(1 \times 10^{-4} \text{ T})(50 \text{ m}) \\
 &= \boxed{\frac{1}{2} \text{ Wb}}
 \end{aligned}$$

Section B

4. A circular loop of wire of radius a lies in the xy -plane centred at the origin. It is immersed in a uniform magnetic flux density $\vec{B} = (0, B_y, B_z)$. A current I is flowing in the loop in a right-handed sense around the positive z -direction, as shown below.

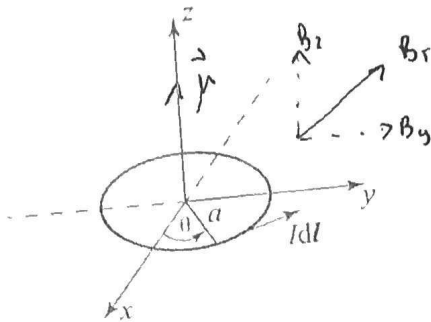

The line element $d\vec{l}$ shown in the figure may be expressed as

$$d\vec{l} = a d\theta [-\sin\theta \hat{i} + \cos\theta \hat{j}],$$

where \hat{i} and \hat{j} are unit vectors along the x and y directions (respectively).

- (a) Find an expression for the magnetic force $d\vec{F}$ on this element. Hence show that the total force on the loop is zero. [You may need to use the next page]. [13]

$$d\vec{F} = I d\vec{l} \times \vec{B} \quad \checkmark$$

$$d\vec{F} = I \langle -\sin\phi a d\phi \hat{i} + \cos\phi a d\phi \hat{j}, 0 \rangle \times \langle 0, B_y, B_z \rangle$$

$$= I \langle -\sin\phi a d\phi B_y \hat{k} + -\sin\phi a d\phi B_z (-\hat{j}) + \cos\phi a d\phi B_z \hat{i} \rangle$$

$$= I \langle 0, +\sin\phi a d\phi B_z + \cos\phi a d\phi B_z, -\sin\phi a d\phi B_y \rangle$$

$$\vec{F}_x = \int 0 = 0 \hat{i}$$

$$\vec{F}_y = \int_0^{2\pi} a B_z (\sin\phi + \cos\phi) d\phi \hat{j}$$

$$= 0 \hat{j} \quad \checkmark$$

$$\vec{F}_z = -a B_y \int_0^{2\pi} \sin\phi d\phi$$

$$= 0 \hat{k}$$

- (b) Write down an expression for the magnetic dipole moment $\vec{\mu}$ of the loop, and hence calculate the total torque $\vec{\tau}$ it experiences. Draw a diagram to indicate the direction of rotation. [12]

$$\vec{\mu} = I \vec{A} \hat{k} \\ = I \pi a^2 \hat{k} \quad \checkmark$$

$$\vec{\tau} = \vec{\mu} \times \vec{B} \\ = \langle 0, 0, I \pi a^2 \rangle \times \langle 0, B_y, B_z \rangle$$

$$= I \pi a^2 B_y (-\hat{i}) + \cancel{I \pi a^2 B_z}$$

$$\vec{\tau} = -I \pi a^2 B_y \hat{i} \quad \checkmark$$

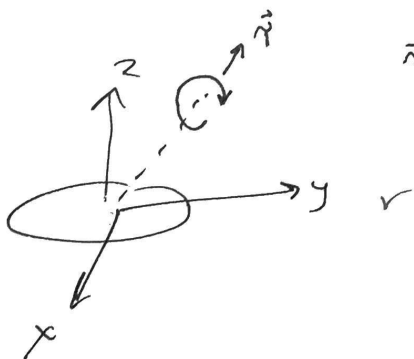

5. Ryan and Bryan are using stationary bicycles as generators to power a set of light bulbs. Ryan's bicycle has its pedals connected directly to the rotating loop of an alternator circuit, which has area A and rotates with angular velocity ω in a magnetic field \vec{B} . This rotating loop is connected via slip rings and brush contacts to a circuit with terminals labelled a and b , as shown in the figure below.

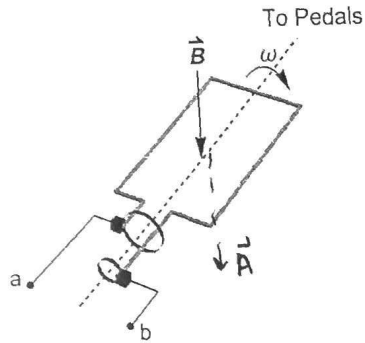

- (a) If Ryan is pedalling at a constant angular velocity ω , find an expression for the induced emf $\mathcal{E}(t)$ around the loop as a function of time. [Assume the vector area of the loop \vec{A} is parallel to \vec{B} at $t = 0$.]

[10]

$$d\Phi = \vec{B} \cdot d\vec{A} \quad \text{correct}$$

$$\Phi = \int \vec{B} \cdot d\vec{A}$$

$$\Phi = \vec{B} \cdot \vec{A} \cos(\omega t)$$

$$\frac{d\Phi}{dt} = -\omega BA \sin(\omega t)$$

$$\mathcal{E} = -\frac{d\Phi}{dt} = \boxed{\omega BA \sin(\omega t)} \quad \checkmark$$

Lenz's law \checkmark

b) Ryan a
same
bulb
b

(b) Ryan and Bryan have identical bicycle generators and are both pedalling at the same angular velocity ω . However, Ryan's circuit is connected to a single light bulb with resistance R , whereas Bryan's circuit is connected to four identical light bulbs in parallel, as shown in the figure below. [Light bulbs are represented by \otimes and the generator is represented by the letter G.]

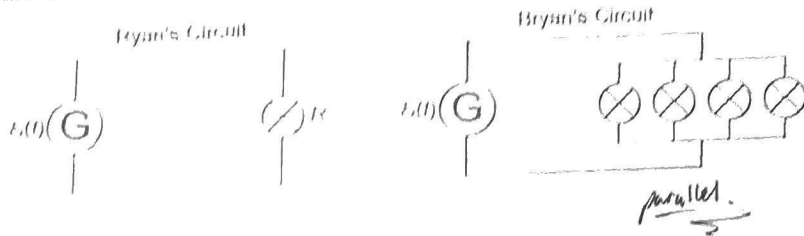

What is the current drawn by each circuit as a function of time, in terms of B , A , ω and R ? [Assume the only resistance in each circuit is due to the lightbulbs]. Find an expression for the peak power delivered to the circuit by each rider. Who is experiencing the largest back torque, and why?

$$E = \omega BA \sin(\omega t)$$

Ryan

$$E = IR$$

$$\frac{E}{R} = I$$

$$\frac{\omega BA \sin(\omega t)}{R} = I_{\text{Ryan}}$$

Peak Power:

$$P = IE$$

$$= \left(\frac{\omega BA \sin(\omega t)}{R} \right) (\omega BA \sin(\omega t))$$

sin max is 1

$$P = \frac{\omega^2 B^2 A^2}{R}$$

Bryan
 $E = IR_{\text{total}}$

$$\frac{E}{R_{\text{total}}} = I$$

$$\frac{4E}{R} = I$$

$$\frac{4(\omega BA \sin(\omega t))}{R} = I_{\text{Bryan}}$$

$$P = EI$$

$$= 4 \left(\frac{\omega BA \sin(\omega t)}{R} \right) (\omega BA \sin(\omega t))$$

$$P = \frac{4\omega^2 B^2 A^2}{R}$$

[15]

$$\frac{1}{R_{\text{total}}} = \frac{1}{R_1} + \frac{1}{R_2} + \frac{1}{R_3} + \frac{1}{R_4}$$

all R are same

$$\frac{1}{R_r} = \frac{4}{R}$$

$$R_r = R/4$$

sin max is 1

Bryan has more back torque since
 $\tau = \vec{\mu} \times \vec{B}$ and $\vec{\mu} \propto I\vec{A}$
 the B 's are the same
 but Bryan has a higher I so he must have a higher back τ

6.

- (a) A long conducting cylindrical wire of radius a carries a current I_0 distributed uniformly across its cross-sectional area. Use Ampère's law to obtain an expression for the magnitude of the magnetic field a distance $r > a$ from the axis outside the cylinder. [10]

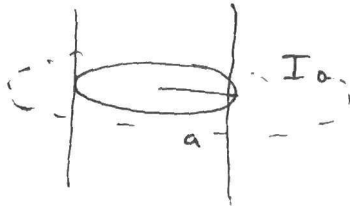

$$\oint \vec{B} \cdot d\vec{l} = I_{enc} \mu_0$$

$$B(2\pi r) = \mu_0 I_{enc}$$

$$B = \frac{\mu_0 I_0}{2\pi r}$$

$\vec{B} = B$
 why?
 -2

✓

- (b) A different long conducting cylindrical wire has a cylindrical cavity along its length, resulting in the cross-section indicated by the shaded area in the diagram below. The wire carries a current I_0 uniformly distributed over its cross-section. Using your result from part (a), or otherwise, derive expressions for the magnitude of the magnetic field at the points A, B and C indicated on the diagram.

[16]

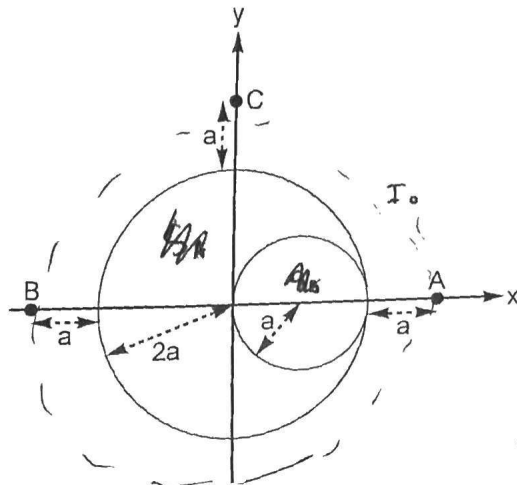

From all

A) magnetic field from S_A is

$$\oint \vec{B} \cdot d\vec{l} = \mu_0 I_{enc}$$

$$(2\pi R)B = \mu_0 J(3\pi a^2)$$

$$2\pi R B = \mu_0 \frac{3\pi a^2 I_0}{3\pi (2a)^2}$$

$$B = \frac{\mu_0 a^2 I_0}{2\pi R (2a^2)}$$

 $R = 3a$

$$B = \frac{\mu_0 a^2 I_0}{2\pi (3a)(2a^2)}$$

$$B = \frac{\mu_0 I_0}{12\pi a}$$

$$I = \int J \cdot dA$$

$$= J(\pi(2a)^2 - \pi a^2)$$

$$= J(\pi 4a^2 - \pi a^2)$$

$$I = J(3\pi a^2)$$

$$\frac{I}{3\pi(2a)^2} = J$$

A) superposition

$$I = \int J dA$$

$$= J(3\pi a^2)$$

$$\frac{\mu_0 I}{2\pi(3a)}$$

-15