

Name: \_\_\_\_\_

Student ID number: \_\_\_\_\_

Discussion section: \_\_\_\_\_

**FINAL EXAM  
PHYSICS 1B, SPRING 2020  
JUNE 10, 2020**

**READ THE FOLLOWING CAREFULLY:**

- ▷ Sign on the second page to affirm that you observe the academic integrity.
- ▷ Open book. Make sure that you work independently on the exam, i.e., no discussion with others.
- ▷ The exam time is between 3pm and 6pm on June 10, Pacific Time.
- ▷ You will have an additional 30 minutes to upload your exam packet. Make sure to submit your exam packet via GradeScope by 6:30pm, June 10, Pacific Time. **No credit will be given for late submissions.**
- ▷ To submit your exam, you have the following three options: (a) Download the PDF from CCLE, print out the PDF, write your solutions in the space provided on the exam packet, scan your packet using a smart phone scanning app such as Adobe Scan, upload your scan to Gradescope. (b) View the PDF on CCLE, write your solutions to all of the problems on loose-leaf, lined or blank paper in precisely the locations you would have written your responses if that paper were the exam packet. Scan and upload your packet of solutions to Gradescope. (c) Download the PDF from CCLE, use a tablet to digitally write your solutions on the PDF, save the PDF with solutions and upload it to Gradescope.
- ▷ **You must make sure that your submission has exactly the same number of pages as the posted exam PDF (including this page and the second page).**
- ▷ **You must justify your answers to each question.** Simply giving the correct answer without proper justification (can be brief) will not result in full credit.
- ▷ Mistakes in grading: If you find a mistake in the grading of your exam, alert the instructor within one week of the exams being returned.

**Academic Integrity - A Bruin's Code of Conduct:**

UCLA is a community of scholars committed to the values of integrity. In this community, all members including faculty, staff, and students alike are responsible for maintaining the highest standards of academic honesty and quality of academic work. As a student and member of the UCLA community, you are expected to demonstrate integrity in all of your academic endeavors. When accusations of academic dishonesty occur, the Office of the Dean of Students investigates and adjudicates suspected violations of this student code. Unacceptable behavior include cheating, fabrication or falsification, plagiarism, multiple submissions without instructor permission, using unauthorized study aids, facilitating academic misconduct, coercion regarding grading or evaluation of coursework, or collaboration not authorized by the instructor. Please review our campus' policy on academic integrity in the UCLA Student Conduct Code: <http://www.deanofstudents.ucla.edu/Student-Conduct-Code>

If you engage in these types of unacceptable behaviors in our course, then you will receive a zero as your score for that assignment. If you are caught cheating on an exam, then you will receive a score of zero for the entire exam. These allegations will be referred to the Office of the Dean of Students and can lead to formal disciplinary proceedings. Being found responsible for violations of academic integrity can result in disciplinary actions such as the loss of course credit for an entire term, suspension for several terms, or dismissal from the University. Such negative marks on your academic record may become a major obstacle to admission to graduate, medical, or professional school.

We cannot make exceptions to our campus' policy on academic integrity, and as we hopefully have communicated effectively here, penalties for violations of this policy are harsh. Please do not believe it if you hear that "everyone does it". The truth is, you usually don't hear about imposed disciplinary actions because they are kept confidential. So our advice, just don't do it! Let's embrace what it means to be a true Bruin and together be committed to the values of integrity.

By submitting my assignments and exams for grading in this course, I acknowledge the above-mentioned terms of the UCLA Student Code of Conduct, declare that my work will be solely my own, and that I will not communicate with anyone other than the instructor and proctors in any way during the exams.

---

Signature

---

Date

---

Print Name

---

UID

[1.] **Short Answer/Conceptual questions. (26 pts)** (Provide *concise* answers to the questions below; you should write enough to explain your answer, but an essay is not required).

- (a) (4 pts) A metal sphere of radius  $a$  is surrounded by a concentric spherical shell of radius  $b > a$  (see below). The metal sphere is given charge  $+Q$  and the spherical shell is given charge  $+4Q$ . A thin conducting wire is used to connect the sphere to the shell and is then taken away. After this, what are the charges on the sphere and the spherical shell? Explain.

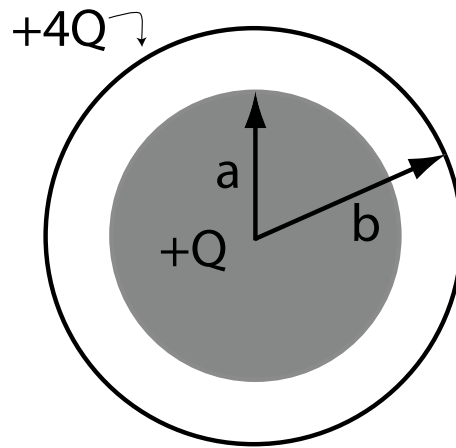

A large empty rectangular box provided for the student to write their answer and explanation.

- (b) (4 pts) A pipe is made up of three cylindrical segments with different cross sections as shown below. The cross-sectional area of each segment can be ranked as  $A_3 > A_1 > A_2$ . The pipe is placed in the horizontal direction. An incompressible, steady flow passes through this pipe.

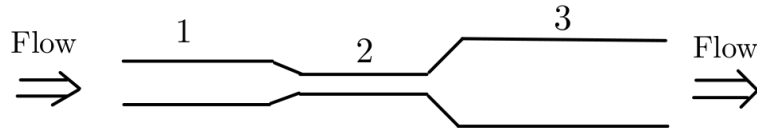

- Rank the volume flow rate  $Q$  (i.e., the volume of the flow per unit time through a cross section) in each segment (compare  $Q_1$ ,  $Q_2$  and  $Q_3$ ).
- Rank the fluid velocity  $v$  in each segment (compare  $v_1$ ,  $v_2$  and  $v_3$ ).
- Rank the fluid pressure  $p$  in each segment (compare  $p_1$ ,  $p_2$  and  $p_3$ ).

- (c) (4 pts) The wave pulse drawn below travels on a taut rope as shown below. It encounters a knot between the rope and a rope which has a larger mass per unit length. Draw the reflected and transmitted waves that results and compare the following properties of these waves to the incident wave: wave speed, amplitude, polarity (upright or inverted), "wavelength" (horizontal extent of the wave).

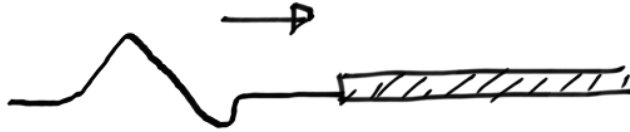

- (d) (4 pts) Two speakers are placed a distance  $L$  apart from one another in a room. They both are driven by the same audio amplifier, creating sound waves at frequency  $f$ . As you walk around the room you hear maxima and minima in sound intensity.
- i. Explain briefly why the sound intensity varies at different locations in the room. What determines where a maximum will occur?
  - ii. You sit down at a spot which is not equidistant from each speaker, but where the intensity is maximum. The room is then filled with a different gas (you hold your breath). The speed of sound in the gas is smaller than in air. The speakers continue to broadcast at the same frequency and intensity. The intensity at your location is still a maximum after the room is filled with the new gas (you walk around to confirm). What has to be true about the speed of sound in the new gas for this to have occurred?

- (e) (4 pts) Two blocks of mass  $M$  are stacked one on top of the other, with the lower block attached to a horizontal spring with spring constant  $k$  (on a frictionless surface). The two masses are put into oscillation with amplitude  $A$  (about  $x = 0$ ), which is low enough such that the two masses do not slip relative to one another. If the top block is removed at the instant the masses reach  $x = A$ , what happens to: (1) the frequency of the oscillation, (2) the amplitude of the oscillation, and (3) the peak velocity associated with the oscillation? Explain.

- (f) (6 pts) Two large conducting plates are separated by a distance  $d$  and are held at a constant potential difference using a battery (which provides EMF  $\mathcal{E}$ ). If I pull the plates apart so that they are now separated by a distance  $2d$ :
- i. What happens to the value of the electric field between the plates and the value of the charge on the plates? (Explain)
  - ii. What happens to the energy stored by the capacitor? (Explain)
  - iii. Is this change consistent with the fact that it is difficult for me to separate the plates (I have to do work to separate the plates)? (Explain)



[2.] (20 pts) Two identical square metal plates with side  $L$  are placed a distance  $h$  from one another as shown (not drawn to scale, you can assume that  $h \ll L$ ). A battery is connected to give total charge  $Q$  to the top plate and  $-Q$  to the bottom plate. The battery is then disconnected (and remains disconnected).

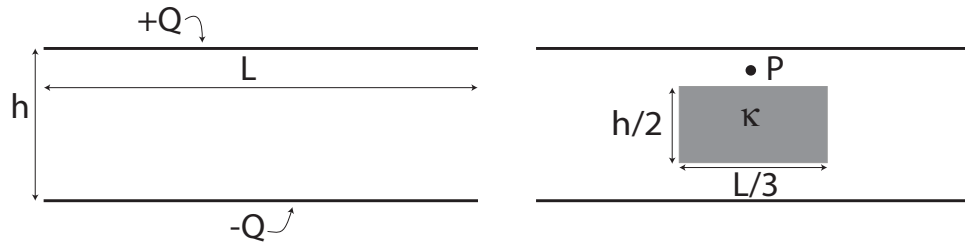

(a) What is the electric field between the plates? What is the potential difference between the plates? What is the capacitance of the two plates?

- (b) I now insert a block of Teflon between the two plates (Teflon has a dielectric constant  $\kappa$ ). The block is rectangular and is  $L$  deep,  $h/2$  tall and  $L/3$  wide. It is placed as shown in the figure above. The block is placed so that its center coincides with the center of the two plates (both vertically and horizontally). Consider the point P as shown in the diagram. What happens to the electric field at that point after I place the dielectric block? Does it increase, decrease, or stay the same relative to the value before the block is inserted? Explain.

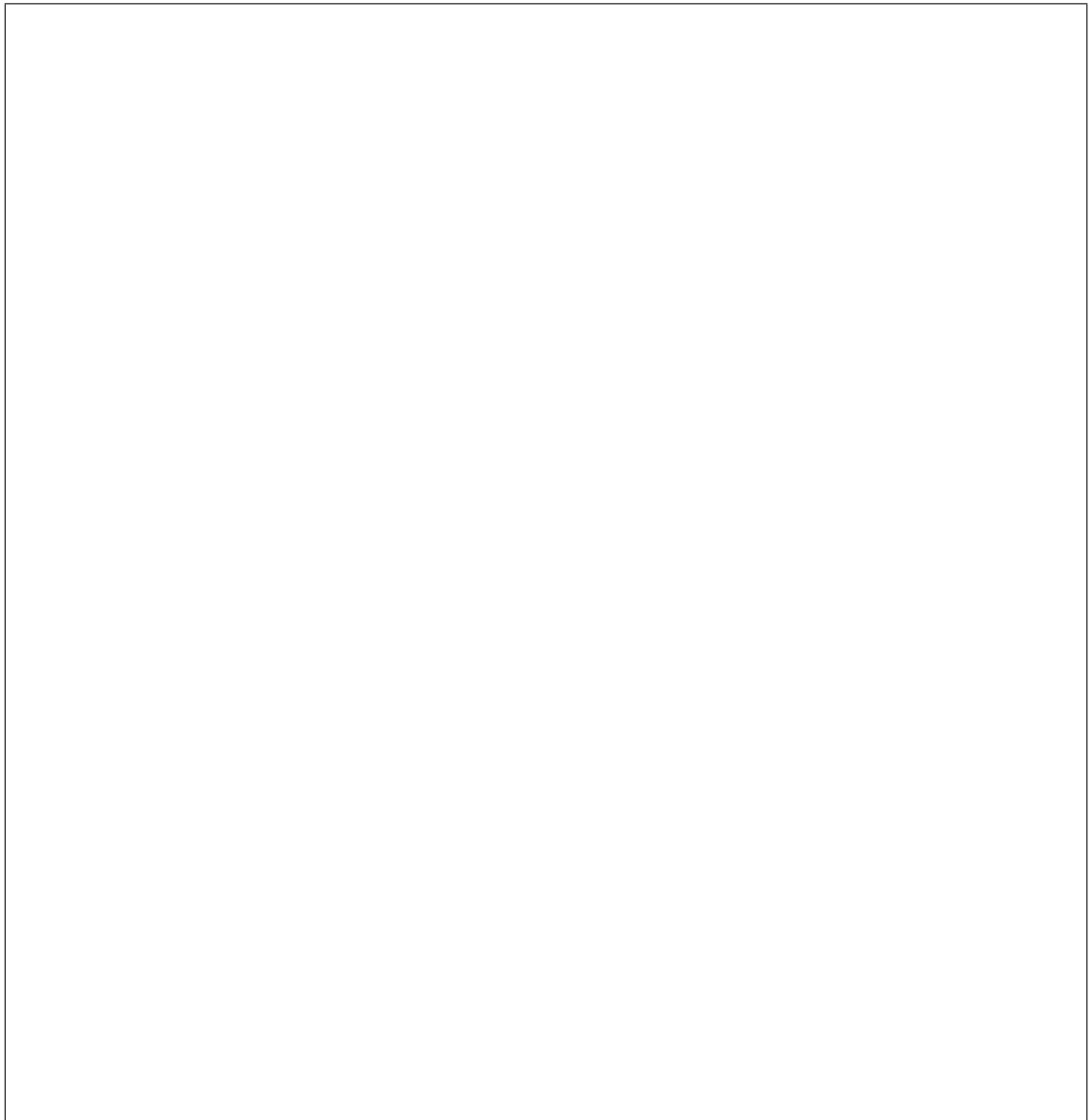

- (c) What is the capacitance of the two plates with the dielectric block present? (Hint: you can ignore "fringing" fields; that is you can assume the electric field retains planar symmetry even with the dielectric block present).

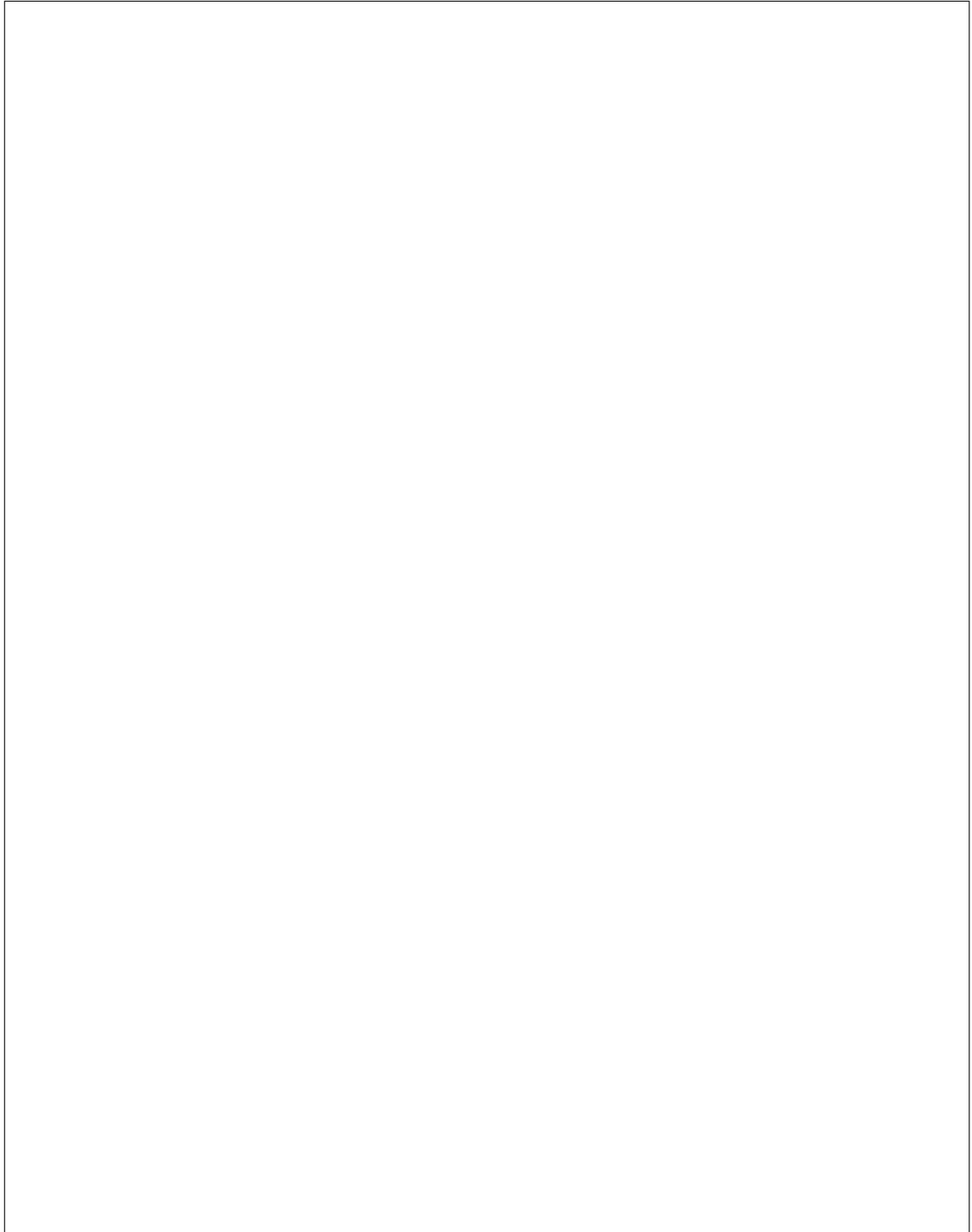

[3.] (16 pts) Consider an electric dipole located in a region of uniform electric field of magnitude  $E$  pointing in the  $+x$  direction, as shown below. The positive and negative ends of the dipole have charges  $+q$  and  $-q$ , respectively, and the two charges are a distance  $D$  apart. The dipole has moment of inertia  $I$  about its center of mass. The dipole is released from the angle  $\theta = \theta_0$ , and it is allowed to rotate freely.

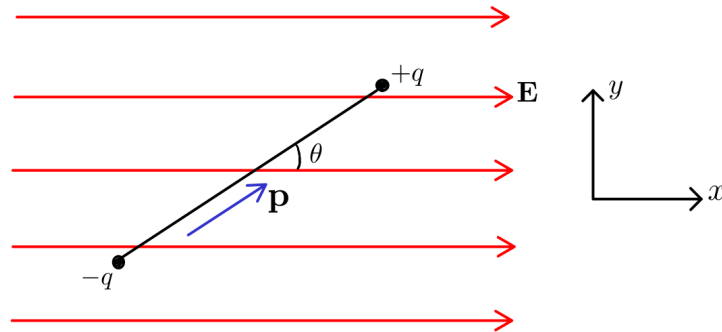

- (a) What is the magnitude of the dipole's angular velocity  $d\theta/dt$  when it is pointing along the  $x$  axis (i.e.,  $\theta = 0$ )? Hint: Use conservation of energy and notice that the electrostatic energy of the dipole in a uniform electric field is  $U = -qDE \cdot \cos \theta$ .

- (b) If  $\theta_0$  is small, the dipole will exhibit simple harmonic motion after it is released. What is the frequency of oscillation? Hint: Draw an analogy between this case and the physical pendulum in a gravitational field.

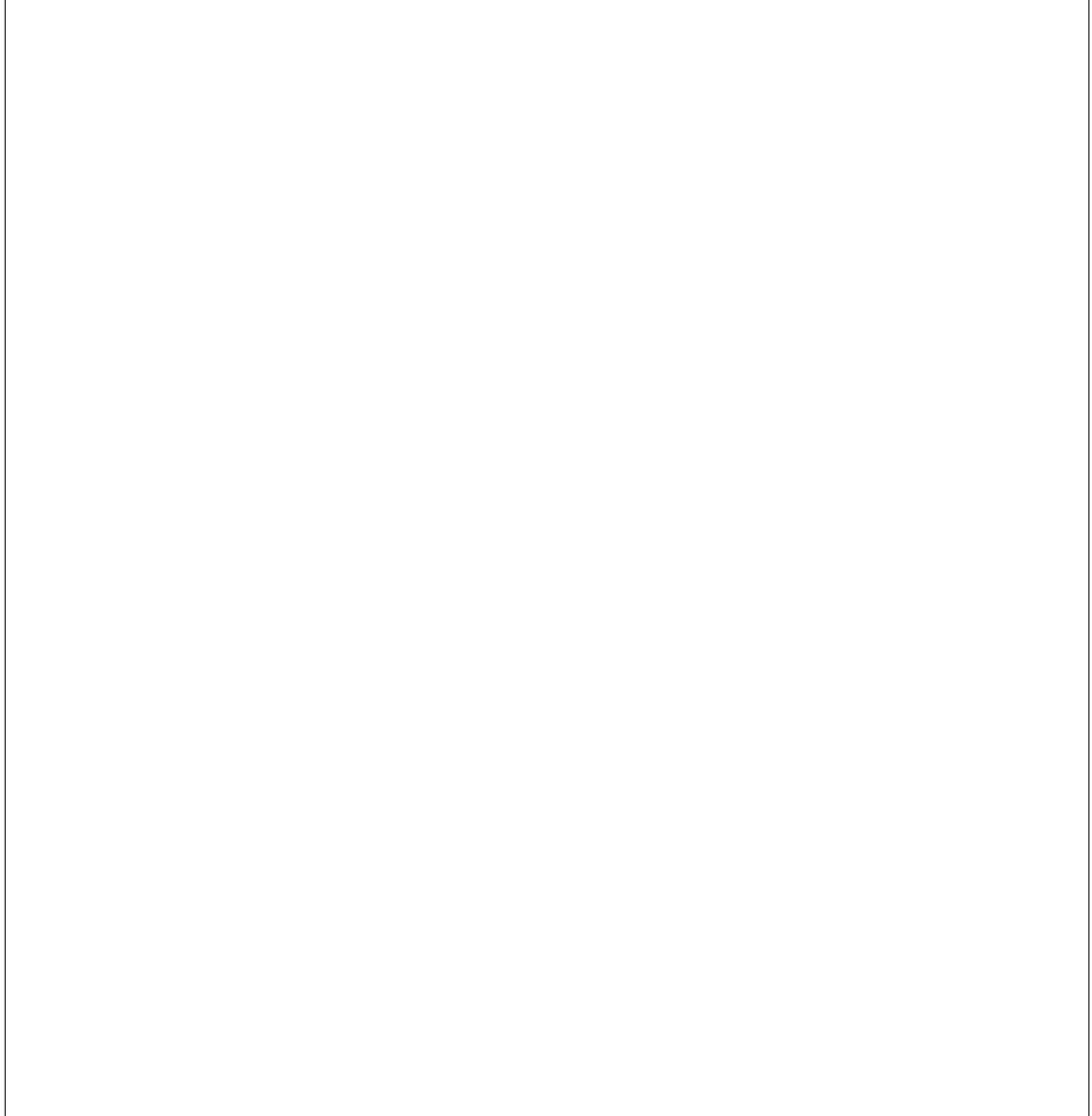

[4.] (18 pts) A tuning fork is found to resonate with the fundamental mode of a tube of length  $L$  which is closed on one end.

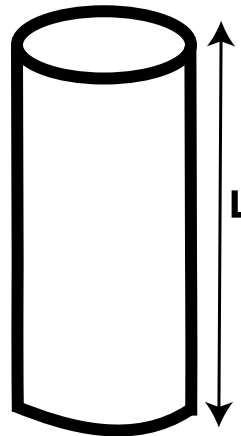

- (a) Draw the pressure perturbation associated with the fundamental mode of this tube (clearly indicate the location of the closed and open ends of the tube). What is the wavelength of this standing sound wave?

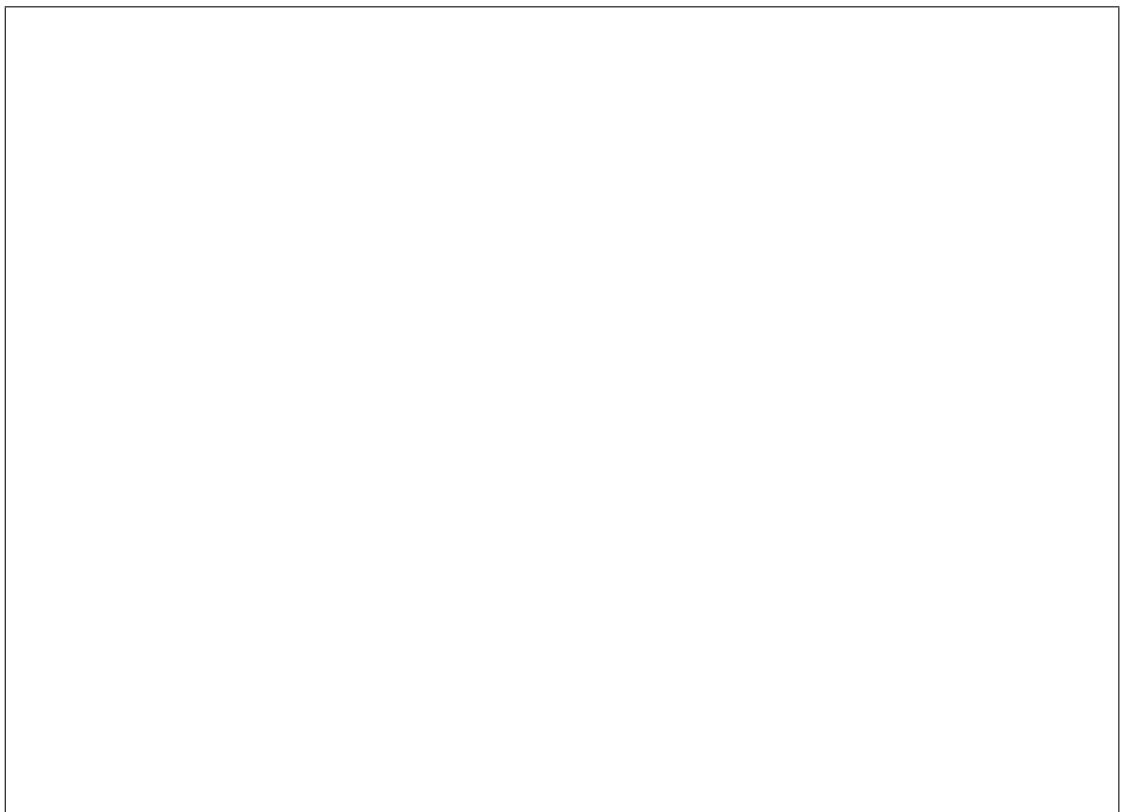

- (b) The tube is then filled with pure Carbon Dioxide gas ( $\text{CO}_2$ ) which has a speed of sound smaller than the sound speed in air. I now want to use the tuning fork to excite the fundamental standing sound wave of the  $\text{CO}_2$ -filled tube; I try to do this by moving the fork with a steady velocity. In which direction should I make this velocity (toward or away from the tube) and why?

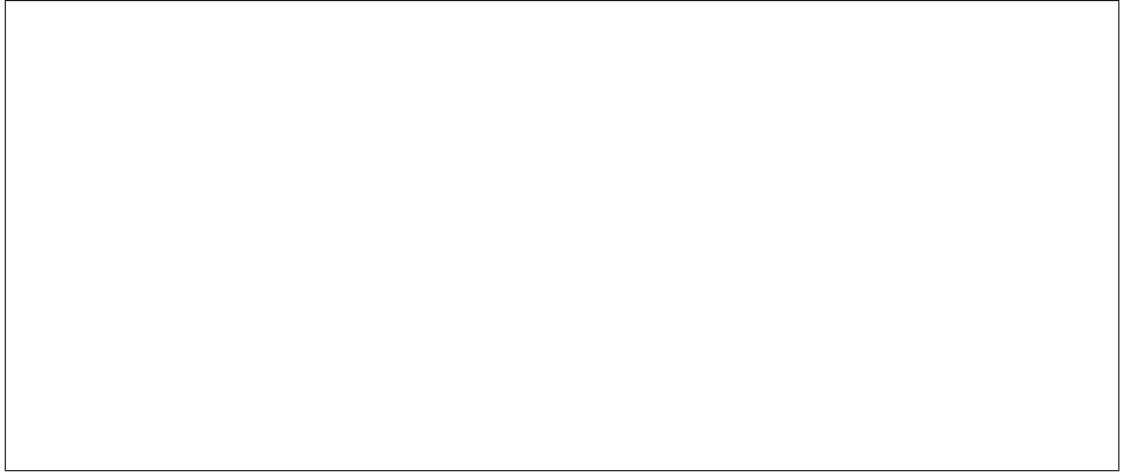

- (c) If the speed of sound in  $\text{CO}_2$  is  $267 \text{ m/s}$ , what is the velocity of the tuning fork that results in exciting the fundamental of the  $\text{CO}_2$ -filled tube?

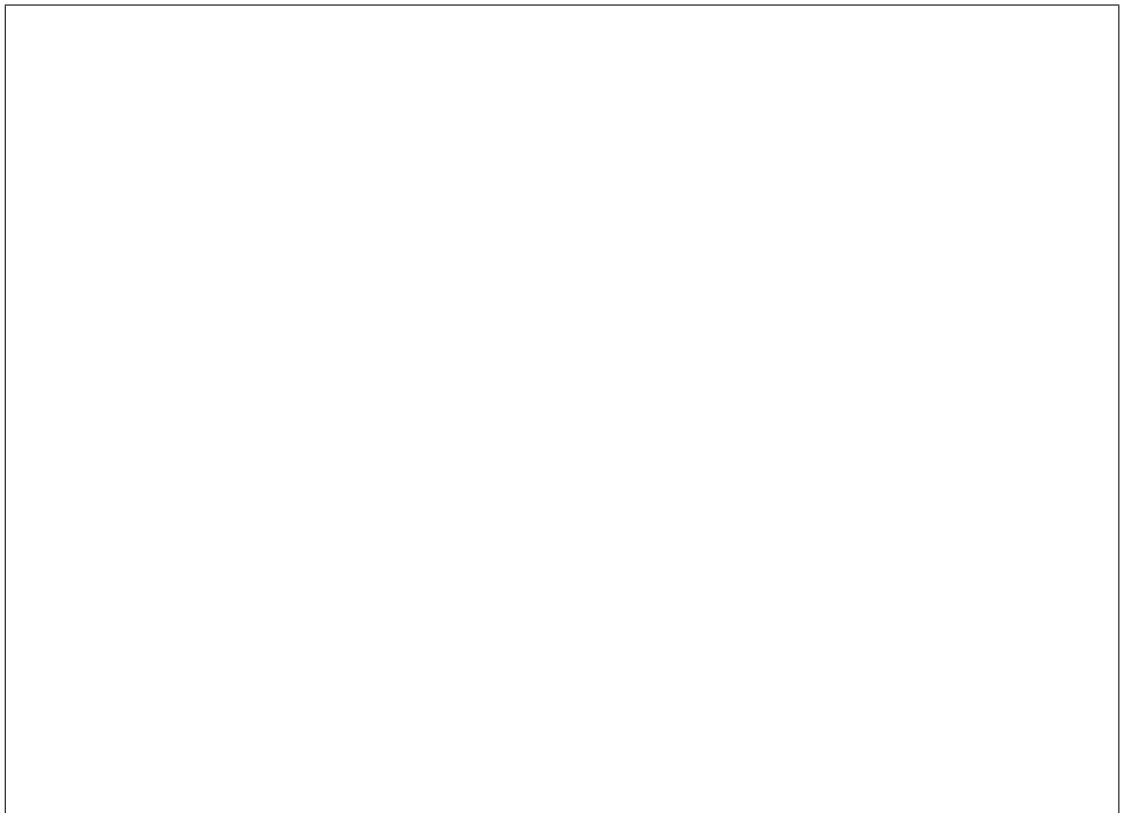

[5.] (20 pts) Consider the circuit below; all bulbs shown have equal resistance  $R$  and the batteries provide EMF  $\mathcal{E}$ .

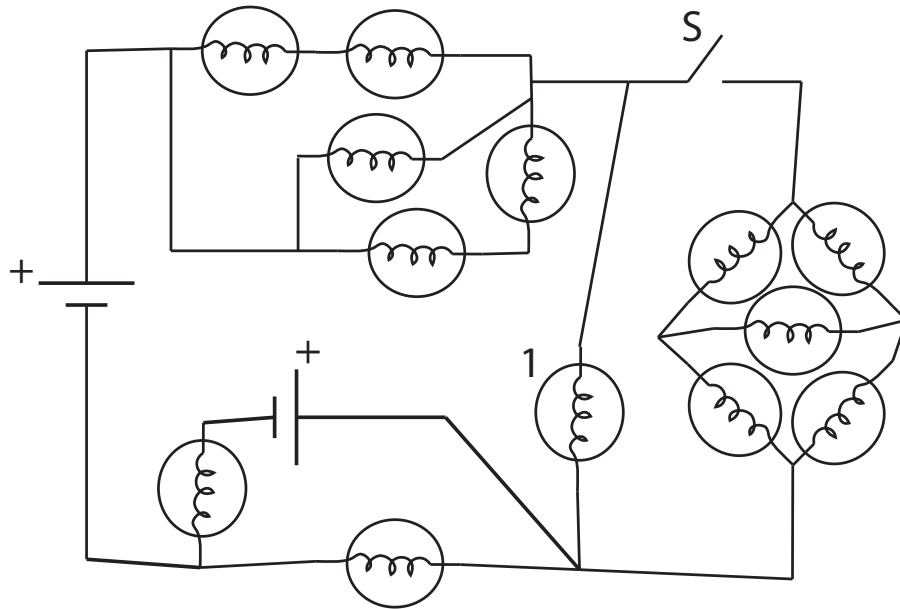

(a) With the switch  $S$  open, what is the current flowing through bulb 1?

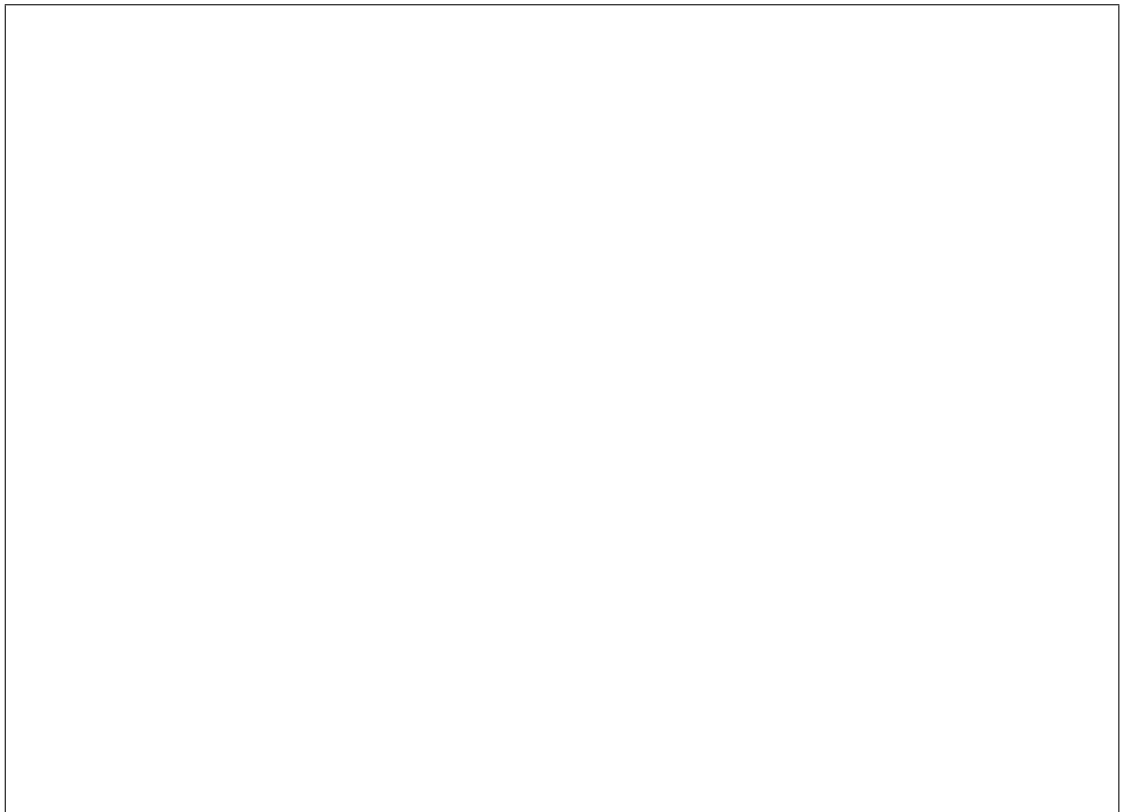



(blank page for extra work space)

**(b)** If I close switch  $S$  (so now it conducts current), what is the new current through bulb 1?

