

Write your name here:

Write your UCLA ID here

Final, Physics 1B, Winter 2020

- Time for exam: 90 minutes (including time to upload the exam to gradescope)
Start time 11:30am (Pacific) and **end time 1:00 pm** (Pacific)
- Please upload all your answers as **single pdf to gradescope**. You can write on the printed out exam, use separate sheets of paper or ipad.
- Please write your name and UID on the top of each sheet you submit.
- Gradescope allows late submissions. This is to accommodate CAE students who have extra time. If you do not have this accommodation please submit by 1pm.
- Open book, you can use the textbook and all the material posted on the class website. Googling answers is not allowed and not helpful
- Calculators allowed, computer algebra systems (Mathematica, Maple) are not.
- Consulting other students for help or collaborating during the exam is not allowed.
- You can ask questions on questionsly, clarifications will be emailed to students
- The exam has 4 questions and 12 pages.
- Useful quantities

$$\begin{aligned}\epsilon_0 &= 8.85 \times 10^{-12} C^2 m^{-2} N^{-1} \\ m_{electron} &= 9.11 \times 10^{-31} kg \\ m_{proton} &= 1.67 \times 10^{-27} kg \\ q_e &= -1.602 \times 10^{-19} C\end{aligned}$$

Good luck !!

Write your name and UID here:

-additional space for calculation-

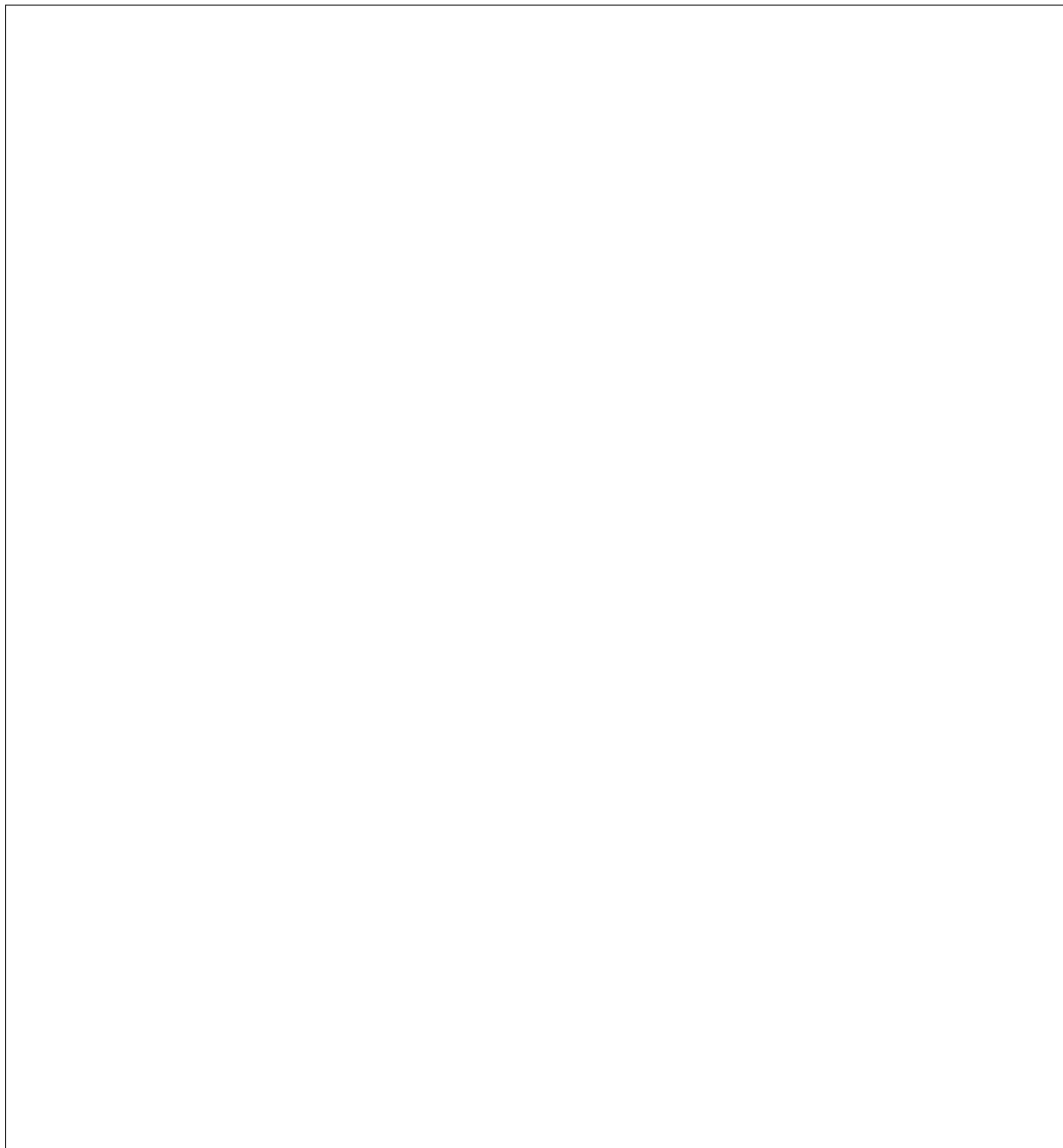

Write your name and UID here:

Problem 1: [15pts] Concept questions

a) [5pts] You have three resistors all with the same resistance R , which are connected by ideal wires (with zero resistance), what is the equivalent resistance of the combination ?

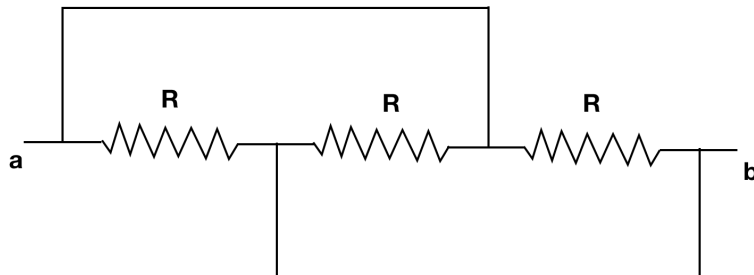

- (1) $3R$
- (2) $\frac{1}{3}R$
- (3) $\frac{2}{3}R$
- (4) $\frac{3}{2}R$
- (5) R

Write your name and UID here:

b) [5pts] Two wires are made out of the same material, the left wire has diameter $d_1 = 3mm$ and the right one has diameter $d_2 = 6mm$, there is a current of $I = 2$ Ampere entering the left wire. What is the relation of the drift velocity v_d^{right} of the electrons of the right wire to the drift velocity v_d^{left} the electrons of the left wire ?

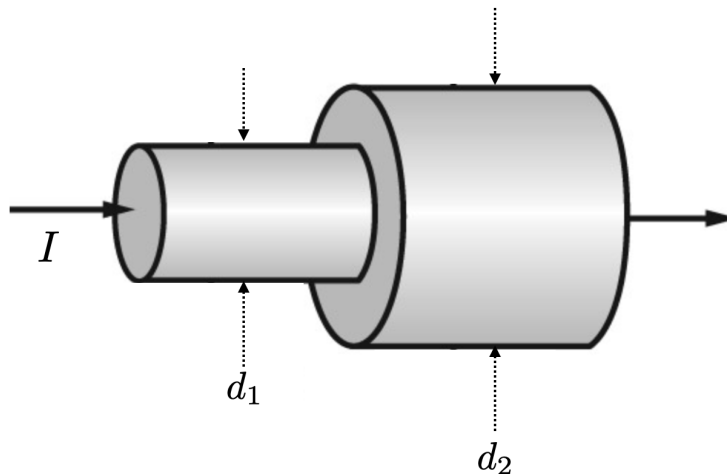

- (1) $v_d^{right} = 2v_d^{left}$
- (2) $v_d^{right} = v_d^{left}$
- (3) $v_d^{right} = 4v_d^{left}$
- (4) $v_d^{right} = \frac{1}{4}v_d^{left}$
- (5) $v_d^{right} = \frac{1}{2}v_d^{left}$
- (6) $v_d^{right} = \frac{1}{\sqrt{2}}v_d^{left}$

Write your name and UID here:

c) [5pts] A loudspeaker broadcasts a sine wave with frequency f_s and a microphone measures the frequency. Consider two situations: a) The loudspeaker is on a cart moving towards the microphone with speed $v = 30m/s$ and the microphone is at rest. b) The microphone on a cart moving towards the loudspeaker with speed $v = 30m/s$ and the loudspeaker is at rest. What is true about the frequency the microphone records in the two cases a) and b) (Denoted as f_a and f_b) ? Assume speed of sound in air is $343 m/s$.

(1) $f_s = f_a = f_b$

(2) $f_a > f_b > f_s$

(3) $f_b > f_a > f_s$

(4) $f_a = f_b > f_s$

(5) $f_a < f_b < f_s$

(6) $f_b < f_a < f_s$

Write your name and UID here:

Problem 2: [30pts] Consider the following circuit, with three ideal batteries with the emf which are multiples of $\epsilon > 0$ (see figure) and three resistors with resistances R_1, R_2, R_3 . As well as a capacitor of capacitance C .

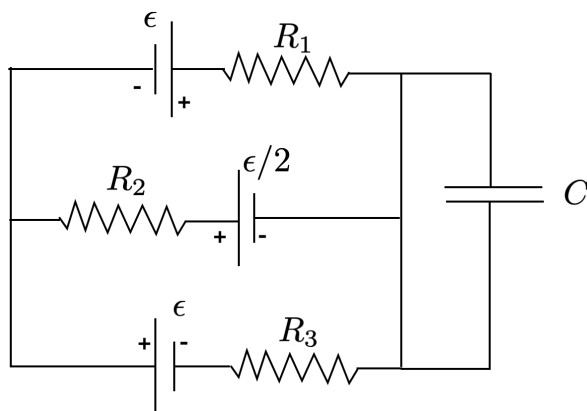

a) [10pts] Label all the currents and their directions in the circuit. Redraw the circuit if you answer on a separate sheet. Use the Kirchhoff junction rule to eliminate as many currents as possible.

Write your name and UID here:

b) [10pts] Use the Kirchhoff loop rule to obtain equations to solve for the remaining currents.

c) [10pts] By choosing the resistances you can make the current through **one** resistor vanishes, which one is it ? Find the relation of the resistances for which this current vanishes. What is the power the battery next to this resistor puts into the circuit (or the circuit puts into the battery) ?

Write your name and UID here:

Problem 3: [30pts] Capacitors

a) [10pts] Consider two fully charged plate capacitors with capacitance C_1, C_2 connected to an ideal battery of emf $\epsilon > 0$. Express the charges q_1, q_2, q_3, q_4 on the four plates in terms of ϵ and C_1, C_2 . Explain in your own words why $q_2 + q_3 = 0$.

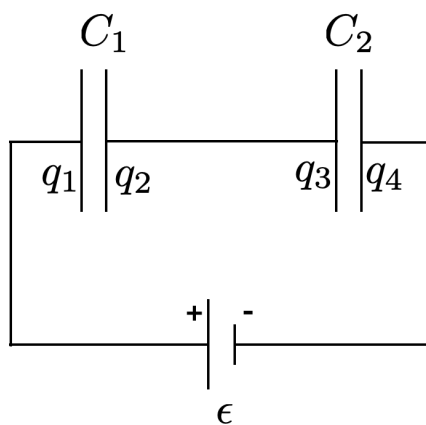

Write your name and UID here:

b) [10pts] You disconnect the fully charged capacitors from the battery and after that insert a dielectric with $K > 1$ in the capacitor C_2 , completely filling the space between the plates. Does the value of q_1, q_2, q_3, q_4 change? Calculate the energy stored in the capacitors after the dielectric is inserted in terms of C_1, C_2, ϵ and K .

Write your name and UID here:

c) [10pts] Consider the following arrangement of fully charged capacitors with capacitances which are multiples of C and connected to an ideal battery with emf ϵ . Calculate the voltage differences $V_c - V_b$ and $V_d - V_b$ in term of ϵ and C .

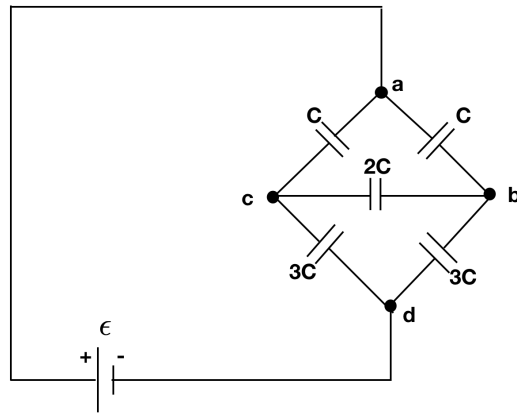

Write your name and UID here:

Problem 4: [20pts] A copper wire of length $l = 1m$ and cross sectional area $6.00 \times 10^{-8}m^2$ is connected to an ideal battery with emf $\epsilon = 1.50V$. The resistivity of copper is $\rho = 1.68 \times 10^{-8}\Omega m$.

a) [10pts] How many electrons flow through a given cross section of the wire in a second ?

b) [10pts] You slowly stretch the wire so that it is 2 meter long (the density stays constant) and connect it to the same battery. (Carefully think what this does to the geometry of the wire) How many electrons flow through a given cross section of the stretched wire in a second ? [If you could not do a) assume $n_e = 7 \times 10^{18}$.]

Write your name and UID here:

-additional space for calculation-

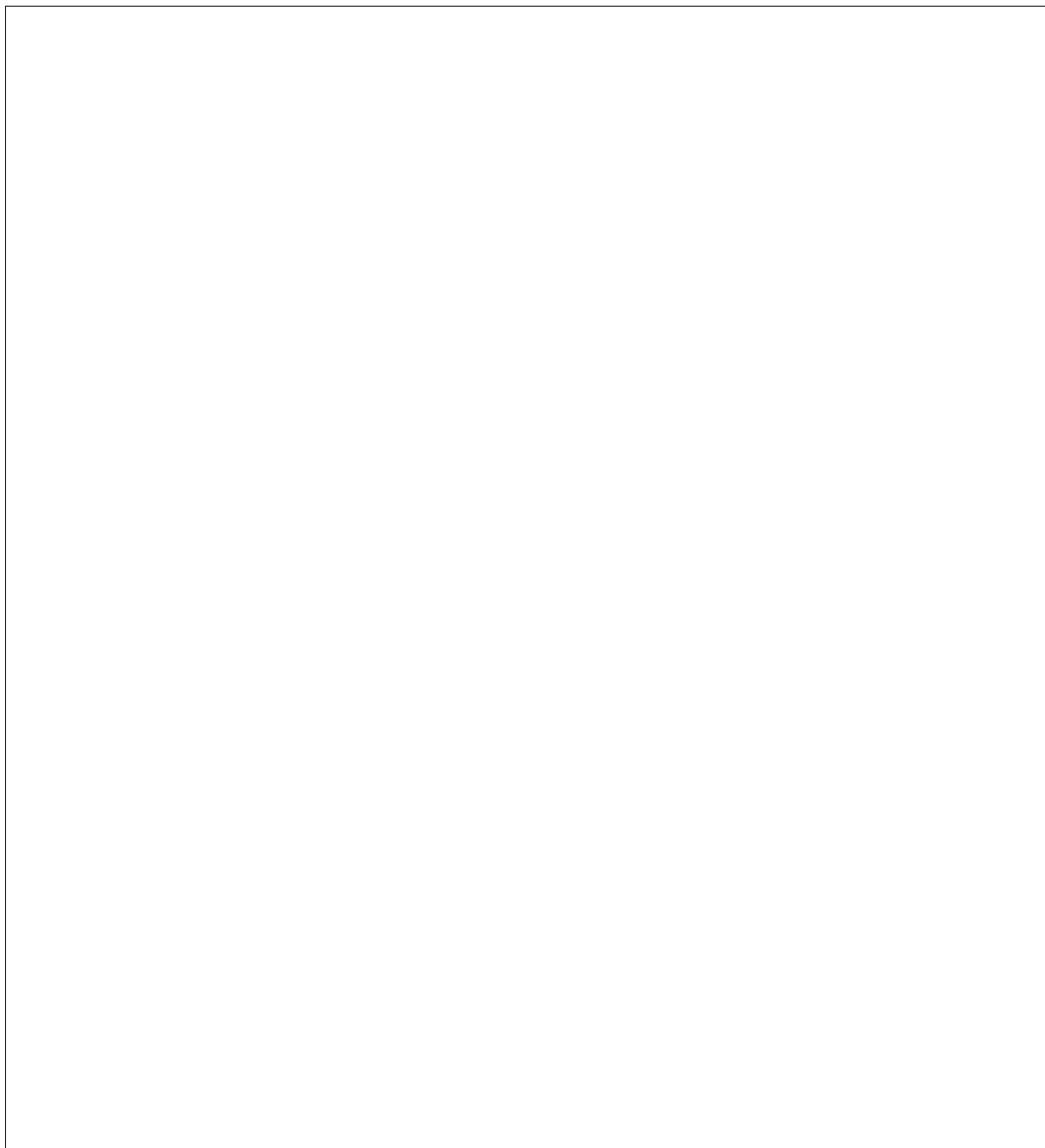
A large, empty rectangular box with a thin black border, intended for providing additional space for calculations.