

ECE113, Digital Signal Processing
UCLA Spring 2021
Midterm Exam
05/04/2021
Time Limit: 24 hours

Name: _____

- (a) This exam contains 9 pages (including this cover page) and 8 problems. Total of points is 100.
- (b) You must scan and submit your solutions in a single file (preferably in PDF format) via the CCLE portal by **2:00pm on 05/05/21 at the latest**.
- (c) Please make sure to write your full name on your papers and also **include it as part of your file name**.
- (d) Please fully justify your answers and clearly show ALL the intermediate steps and calculations in all your solutions. And, when appropriate, box your final answer.
- (e) Feel free to use any calculators and computers, including MATLAB. But please always make sure to explain your approach and present all your intermediate steps.
- (f) Note that some of the different parts in multi-part problems may be solved independently of the other parts.
- (g) Open books and notes, but no collaboration please. You are expected to work on the solutions individually. Unreasonably similar write-ups and calculation steps would be heavily penalized on all parties suspected of collaboration.
- (h) **Good Luck...**

Grade Table (for instructor use only)

Question	Points	Score
1	10	
2	18	
3	15	
4	12	
5	10	
6	14	
7	8	
8	13	
Total:	100	

1. (10 points) **Quick Review**

Carefully read each statement below and identify it as *True* or *False*, and briefly explain your reason in one or two sentences.

1. Discrete-time sinusoids are always periodic in time.

True or False? Why?

2. Discrete-time Fourier Transforms are always periodic in frequency.

True or False? Why?

3. A finite-precision Direct Form I realization of a digital filter will have a higher chance for internal overflow compared to Direct Form II.

True or False? Why?

4. Regardless of the window function used, zero-padding a discrete-time sequence will always lead to smaller spectral leakage.

True or False? Why?

5. The phase of the DTFT of an even-symmetric real-valued signal will always be 0 or 180° .

True or False? Why?

6. Downsampling a lowpass sequence by a factor D will never lead to aliasing as long as the discrete-time sequence does not have any energy within the the frequency range of $[\frac{\pi}{D}, \pi]$ rad/sample.

True or False? Why?

7. Upsampling by a factor I may lead to aliasing if the discrete-time sequence has any energy within the frequency range of $[\frac{\pi}{I}, \pi]$ rad/sample.

True or False? Why?

8. Any discrete-time sequence of length N or less can always be represented by its N -point DFT.

True or False? Why?

9. The *minimum* sampling rate to avoid aliasing for a real-valued *bandpass* signal with its single-side band (i.e., over positive frequencies) limited to B (i.e., $F_H - F_L = B$) Hz would always be $2B$.

True or False? Why?

10. An N -point *circular convolution* of a sequence with length N_1 with another sequence of length N_2 will always be equal to the *linear convolution* of the two sequences within the range $[0, N - 1]$ as long as $N \geq \max(N_1, N_2)$.

True or False? Why?

2. (18 points) **LCCDE, Direct Form Structures:**

A second-order LTI system is described by the following Linear Constant Coefficient Difference Equation:

$$y(n] - 0.1y(n - 1) - 0.72y(n - 2) = 5x(n - 1) \quad (1)$$

Assume the following initial conditions for the system:

$$y(-2) = 1.25, \quad y(-1) = -1$$

- (3 points) Write the characteristic equation of the system, find the natural frequencies (modes), and write the form of the homogeneous response of the system.
- (1 point) Is this system BIBO stable? Why or why not?
- (6 points) Find the complete system response, $y(n)$, $n \geq 0$, to the input sequence $x(n) = (\frac{1}{5})^n u(n)$, where $u(n)$ is the unit step sequence.
- (1 point) How would the form of the response change if the input was $x(n) = 0.9^n u(n)$ instead? You don't need to find the values of the constants again. Just indicate if you think the form of the response would change and if so, how?
- (4 points) Given the same initial conditions and the same input as in Part (c), determine the *zero-input* and the *zero-state* responses of this system.
- (3 points) Draw the signal flow graph for the *Transposed Direct Form II* realization of this system.

3. (15 points) **LTI Systems, DTFT, Frequency Response:**

The impulse response of an LTI system, $h(n)$, is shown below ($h(n) = 0$ for all other time indices not shown on the plot):

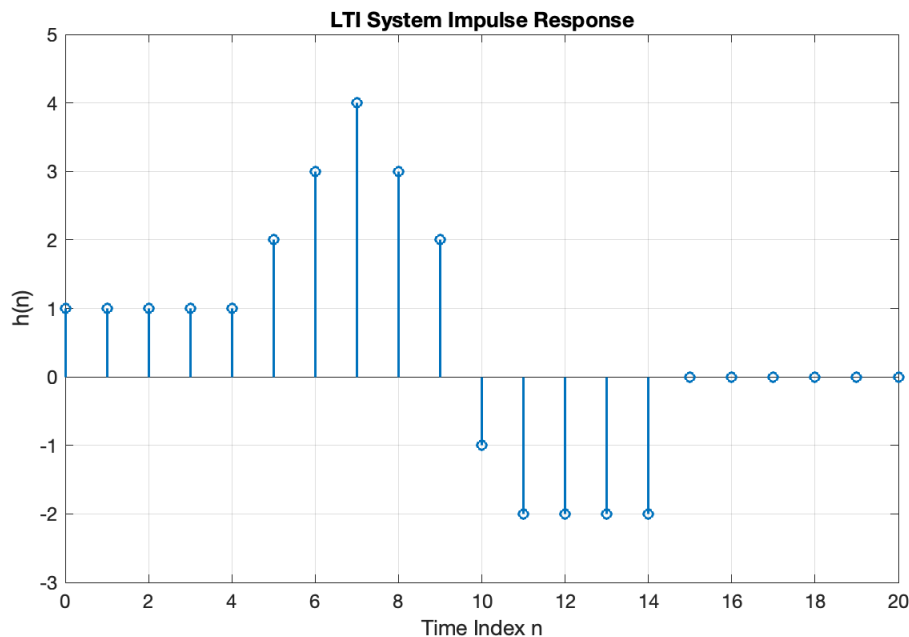

- (a) (1 point) Is this system causal? Why or why not?
- (b) (1 point) Is this system BIBO stable? Why or why not?
- (c) (6 points) Obtain the system frequency response $H(\omega)$ in closed form (i.e., no Σ 's). (*Hint:* Try to represent $h(n)$ in terms of some known signals for which you may already know the DTFT, and take advantage of the DTFT properties.)
- (d) (3 points) Using MATLAB, plot the magnitude and phase responses for this system over the frequency range $-\pi \leq \omega \leq \pi$ (rad/sample).
- (e) (4 points) Determine the *steady-state* response of this system to the following input signal:

$$x(n) = 1 + 5(-1)^n + \sin\left(\frac{\pi}{2}n\right) \quad (2)$$

4. (12 points) **Autocorrelation, DTFT:**

For this problem, you need to think about the properties of autocorrelation sequences, including the correlation property of DTFT.

- (a) (2 points) Can the discrete pulse sequence below be a valid autocorrelation sequence? Why or why not? Please explain.

$$r_{xx}(n) = u(n) - u(n - N) = \Pi\left(\frac{n - \frac{N-1}{2}}{N}\right) \quad (3)$$

$u(n)$ is the unit step sequence, and Π denotes a pulse. Assume N odd.

- (b) (2 points) How about the following pulse sequence centered around $n = 0$? Can it be a valid autocorrelation sequence? Why or why not? Please explain.

$$r_{xx}(n) = u(n + N) - u(n - N - 1) = \Pi\left(\frac{n}{2N + 1}\right) \quad (4)$$

- (c) (2 points) How about the following triangle sequence? Can it be a valid autocorrelation sequence? Why or why not? Please explain.

$$r_{xx}(n) = \Lambda\left(\frac{n}{2N + 1}\right) = \begin{cases} (1 - \frac{|n|}{N}) & |n| \leq N \\ 0 & \text{otherwise} \end{cases} \quad (5)$$

- (d) (3 points) Consider a discrete-time sequence $x(n)$, and assume $y(n)$ to be its delayed version, i.e., $y(n) = x(n - n_0)$. Write the autocorrelation sequence for $y(n)$ in terms of the autocorrelation for $x(n)$, i.e., write $r_{yy}(n)$ in terms of $r_{xx}(n)$.
- (e) (3 points) Given a discrete-time sequence $x(n)$, let $y(n) = e^{j\omega_0 n}x(n)$. Again, write $r_{yy}(n)$ in terms of $r_{xx}(n)$.

5. (10 points) **DFT Spectral Analysis:**

A system for discrete-time spectral analysis of a continuous-time signal is shown below:

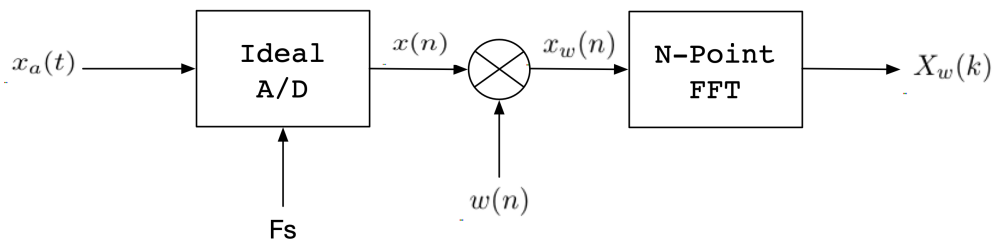

where $w(n)$ is the window function. We have implemented this system in the MATLAB code snippet shown below:

```

N = 64; % Number of Points in DFT
Fs = 8500; % Sampling Rate (Hz)
F1 = 1800; % First tone frequency (Hz)
F2 = 2000; % Second tone frequency (Hz)
t = 0:1/Fs:(N-1)/Fs; % Time vector (sec)
Fx = 0:Fs/N:Fs*(N-1)/N; % Frequency vector (Hz)
xn = sin(2*pi*F1*t)+0.05*sin(2*pi*F2*t); % The time-domain signal
xn_noisy = awgn(xn,10); % with AWGN added with SNR=10dB
wr = rectwin(N); % Rectangular Window
xn_r = xn_noisy.*wr'; % Windowed time-domain signal
Xk = fft(xn_r,N); % N-point FFT calculation

% Plot the power spectrum
plot(Fx,10*log10(abs(Xk).^2),'LineWidth',1.5);
title('Power Spectrum for x(n)');
xlabel('F (Hz)');
ylabel('10log(|X|^2) (dB)');
grid on;
xlim([0,Fs]);

```

As shown in the code, we have obtained the 64-point FFT of a two-tone signal corrupted with Additive White Gaussian Noise (AWGN). One run of this code has produced the following power spectrum plot:

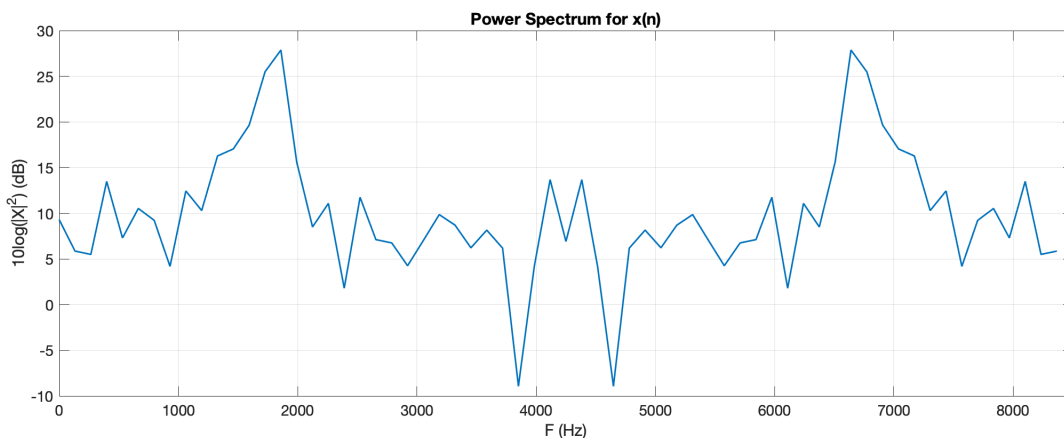

Clearly the above spectral representation leaves much to be desired and one would have a hard time identifying the two tones in the signal.

Suppose you cannot change anything with the signal itself. That is, you have the given two-tone signal, sampled at the rate of $F_s = 8.5$ KHz, and with 10dB Signal-to-Noise Ratio (SNR).

- (4 points) Describe **ALL** the different techniques you can use to improve the spectral representation of this signal, and explain how each technique can help.
- (6 points) Use the given code as your starting point (you can download it from CCLE if you don't want to type again!), and modify it by implementing the different techniques you proposed in Part (a), and show how you have improved the spectral representation of the given signal. Please include a printout of your modified MATLAB code along with the improved spectral plot and discuss.

6. (14 points) **DTFT, Sample Rate Conversion:**

Consider the system below where two continuous-time signals $x_a(t)$ and $y_a(t)$, with the given spectrum (CTFT) are first sampled at different rates, then downsampled and upsampled respectively in order to have the same sampling rate, also multiplied by tones, and eventually passed through an ideal highpass and an ideal lowpass filter respectively, and finally added up, forming a composite signal $z(n)$.

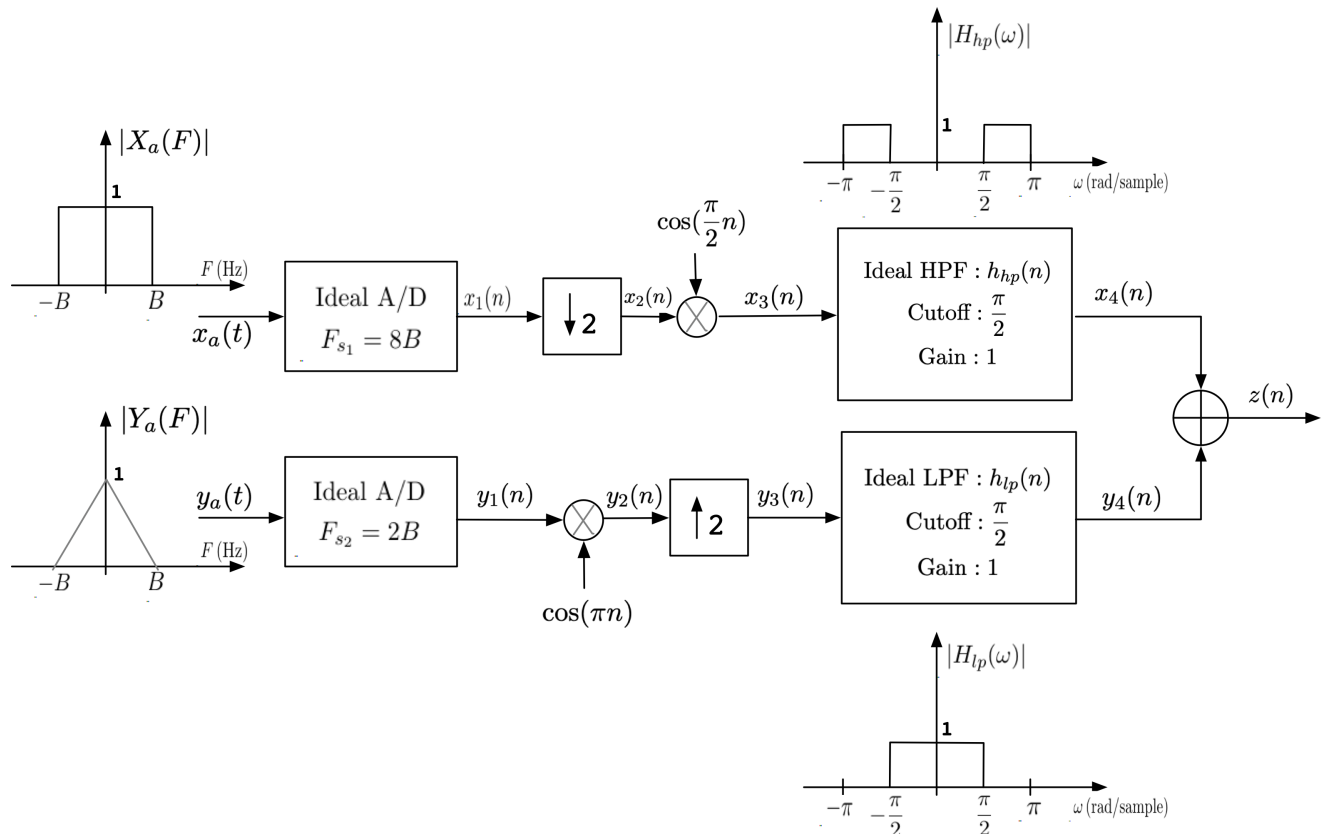

- (a) (8 points) Plot the magnitude DTFT of $x_1(n)$, $x_2(n)$, $x_3(n)$, $y_1(n)$, $y_2(n)$, and $y_3(n)$ over $-2\pi < \omega < 2\pi$, showing as much detail as possible, including all important corner and/or center frequencies as well as the magnitudes. Show the important points on the frequency axis both in terms of rad/sample as well as Hertz.
- (b) (2 points) Plot the magnitude DTFT of the composite signal $z(n)$ over $-2\pi < \omega < 2\pi$, showing as much detail as possible.
- (c) (4 points) Can you draw a block diagram of a similar system (i.e., using ideal filters, downsampling/upsampling, and modulation) that can be used to recover the individual signals $x_1(n)$ and $y_1(n)$ from the composite signal $z(n)$?

7. (8 points) **DFT/IDFT, Linear vs. Circular Convolution:**

Orthogonal Frequency Division Multiplexing (OFDM) is a digital transmission scheme used in many modern communication systems, including WLAN and LTE/5G cellular systems. It is a scheme where the high-rate data is partitioned and transmitted over multiple orthogonal narrowband (lower-rate) subcarriers. Its main benefit is to cope with severe multipath fading channels without requiring complex channel equalization filters. The diagram below shows the high-level architecture for a typical WLAN OFDM transmitter and receiver.

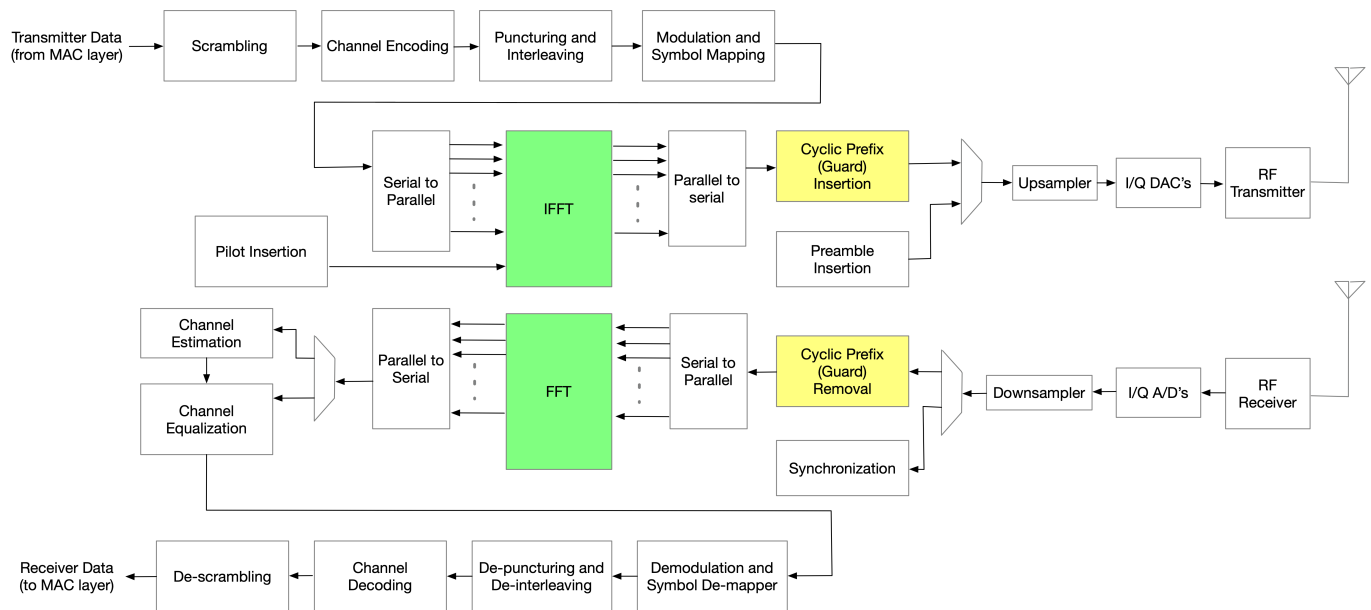

For this problem, we are only focusing on the colored blocks, i.e., FFT/IFFT and Cyclic Prefix insertion/removal. As shown, on the transmitter side, an Inverse-FFT (IFFT) block is used to generate the OFDM symbols. In doing so, the samples to be transmitted are treated as the frequency-domain scalings on the different subcarriers, and the IFFT block then generates the corresponding OFDM symbols in the time domain. As shown, the opposite occurs on the receiver side, where an FFT engine translates the time-domain received samples into the frequency domain whereby the scalings on the different

subcarriers (based on the received OFDM symbol) will then be processed through the receiver chain and the received bits will ultimately be decoded and passed onto the higher layers.

- (a) (5 points) For Time Division Duplexing (TDD) systems such as WLAN, which can only transmit or receive at any given instant, i.e., no simultaneous transmit/receive, an efficient hardware implementation would be to re-use the same FFT engine for both Inverse-FFT processing in the transmitter and the FFT processing in the receiver. Using the DFT definition, show why/how the following implementation would actually work. $x(n)$'s are the time-domain samples and $X(k)$'s are the corresponding DFT samples.

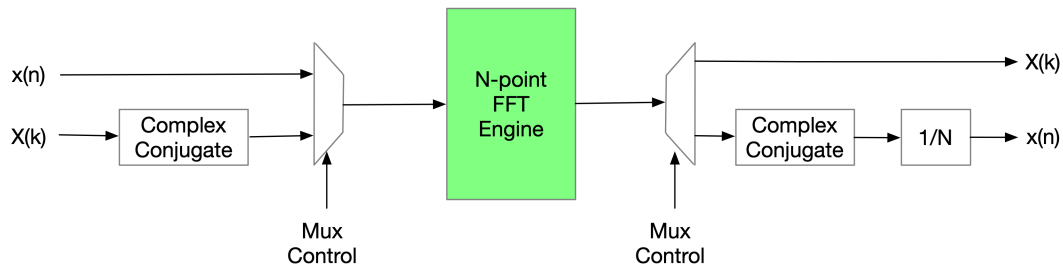

- (b) (3 points) Also shown in the WLAN transceiver architecture are the *Cyclic Prefix* insertion (on Tx side) and removal (on Rx side). The Cyclic Prefix appends a portion at the end of the OFDM symbol to its beginning. This is shown in the figure below (copied from dspillustrations.com).

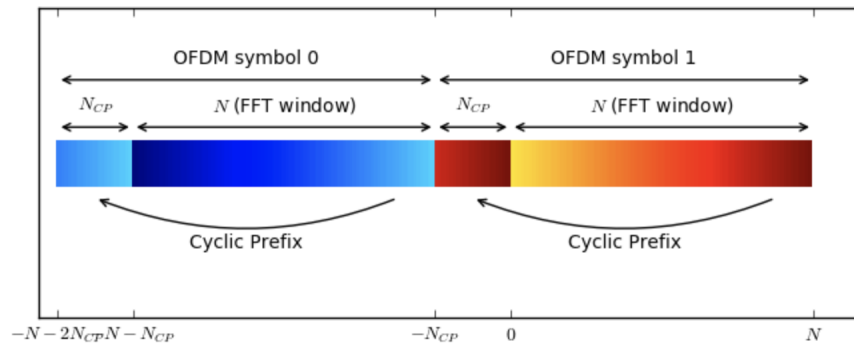

One purpose for this is just to add Guard Interval between consecutive OFDM symbols in order to avoid *inter-symbol interference*. But the guard interval did not have to be in the particular format of a Cyclic Prefix. So another key purpose for Cyclic Prefix insertion has to do with linear versus circular convolution. Note that we may model our wireless channel as an LTI system with frequency response samples (i.e., DFT) of $H(k)$. So from what you know about linear versus circular convolution, can you explain the second benefit of inserting the Cyclic Prefix in the OFDM symbol?

8. (13 points) **Sampling, DFT, FFT:**

Sampling a continuous-time baseband (lowpass) signal, $x_a(t)$, over a duration of 1 second, has generated 4096 samples.

- (a) (2 points) Assuming there was no aliasing, what would be the highest frequency in the spectrum of $x_a(t)$?
- (b) (2 points) If we obtain the 4096-point FFT of the available samples, what would be the frequency spacing in Hertz between each two adjacent frequency bins?
- (c) (2 points) Suppose we are only interested in the frequency bins within the range $100 \leq F \leq 500$ Hz. How many complex multiplications would be needed to calculate these frequency bins using the direct 4096-point DFT computation?
- (d) (2 points) How many complex multiplications would be needed to obtain all 4096 bins if we use *Decimation-in-Time* Radix-2 4096-point FFT algorithm instead? Compare with the number you found in Part (c) for only a subset of frequency bins.
- (e) (2 points) How many complex multiplications would be needed to obtain all 4096 bins if we use *Decimation-in-Frequency* Radix-2 4096-point FFT algorithm instead? Compare with your numbers in Part (c) and (d).
- (f) (3 points) Suppose we only need m bins from an N -point FFT. What would be the largest m (expressed in terms of N) before the Decimation-in-Time Radix-2 N -point FFT becomes more computationally efficient than the direct N -point DFT calculation? What would be the actual value for the 4096-point DFT (i.e., $N = 4096$) in this problem?