

**ECE102, Fall 2020**

Department of Electrical and Computer Engineering  
University of California, Los Angeles

**Final Exam**

Prof. J.C. Kao  
TAs: A. Ghosh, T. Monsoor & G. Zhao

UCLA True Bruin academic integrity principles apply.

Open: Notes, Book.

Closed: Internet, except to use Piazza and CCLE.

3:00-6:00pm.

Wednesday, 16 Dec 2020.

State your assumptions and reasoning.

No credit without reasoning.

Name: \_\_\_\_\_

Signature: \_\_\_\_\_

ID#: \_\_\_\_\_

Problem 1 \_\_\_\_\_ / 50

Problem 2 \_\_\_\_\_ / 50

Problem 3 \_\_\_\_\_ / 54

Problem 4 \_\_\_\_\_ / 46

BONUS \_\_\_\_\_ / 15 bonus points

Total \_\_\_\_\_ / 200 points + 15 bonus points

1. Signal and System Basics (50 points)

- (a) (16 points) Consider an LTI system whose response to the signal  $x_1(t)$  in Figure (1a) is the signal  $y_1(t)$  illustrated in Figure (1b).

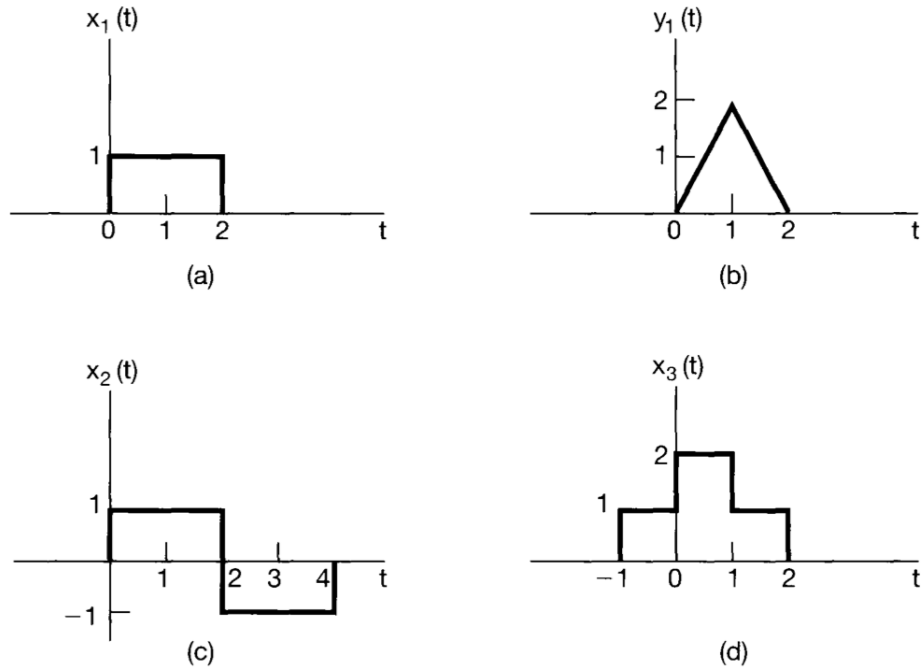

Figure 1: Input-output relationship

- i. (8 points) Determine and sketch the response of the system to the input  $x_2(t)$  shown in Figure (1c).

- ii. (8 points) Determine and sketch the response of the system to the input  $x_3(t)$  shown in Figure (1d).

(b) (24 points) For each statement below, determine whether it is true or false. You must justify your answer to receive full credit.

i. (8 points) If  $T_1(x)$  and  $T_2(x)$  are LTI systems, then  $T_2(T_1(x))$  must be LTI.

ii. (8 points) If  $T_1(x)$  and  $T_2(x)$  are nonlinear systems, then  $T_2(T_1(x))$  must be nonlinear.

- iii. (8 points) Consider a time-invariant system with input  $x(t)$  and output  $y(t)$ . If  $x(t)$  is periodic with period  $T$ , then  $y(t)$  is also periodic with period  $T$ .

- (c) (10 points) The signal  $y(t)$  is generated by convolving a band-limited signal  $x_1(t)$  with another band-limited signal  $x_2(t)$ , that is:

$$y(t) = x_1(t) * x_2(t) \quad (1)$$

where,

$$X_1(j\omega) = 0 \text{ for } |\omega| > 1000\pi$$

$$X_2(j\omega) = 0 \text{ for } |\omega| > 2000\pi$$

Next,  $y(t)$  is sampled via an impulse train to obtain

$$y_p(t) = \sum_{n=-\infty}^{+\infty} y(nT)\delta(t - nT)$$

Specify the range of values for the sampling period  $T$  which ensures that  $y(t)$  is recoverable from  $y_p(t)$ .

2. **Fourier transform, Frequency response and Output of LTI systems** (50 points)

(a) (30 points) Consider an LTI system with the impulse response:

$$h(t) = \left( \frac{\pi \sin(5t) \sin(15t)}{5 \pi t \pi t} \right) 2j \sin(20t)$$

i. (5 points) Show that

$$\frac{\pi \sin(5t) \sin(15t)}{5 \pi t \pi t} = \frac{15}{\pi} Sa(5t) Sa(15t)$$

where  $Sa(t) = \frac{\sin(t)}{t}$ .

ii. (15 points) Compute the Fourier transform of

$$\frac{\pi}{5} \frac{\sin(5t)}{\pi t} \frac{\sin(15t)}{\pi t}$$

You must indicate which properties and pairs you are using to arrive at your answer. You must show all steps to receive credit.

*Hint: You may find the following Fourier Transform useful.*

$$\frac{B}{2\pi} \text{Sa}\left(\frac{Bt}{2}\right) \iff \text{rect}\left(\frac{\omega}{B}\right)$$



- iii. (10 points) Use the properties of Fourier transform to determine the frequency response  $H(j\omega) = \mathcal{F}[h(t)]$  and plot it on graph on the next page. You must indicate which property you are using to arrive at your answer. You must show all steps to receive credit. For your convenience, recall that  $h(t)$  is:

$$h(t) = \left( \frac{\pi \sin(5t)}{5} \frac{\sin(15t)}{\pi t} \right) 2j \sin(20t)$$

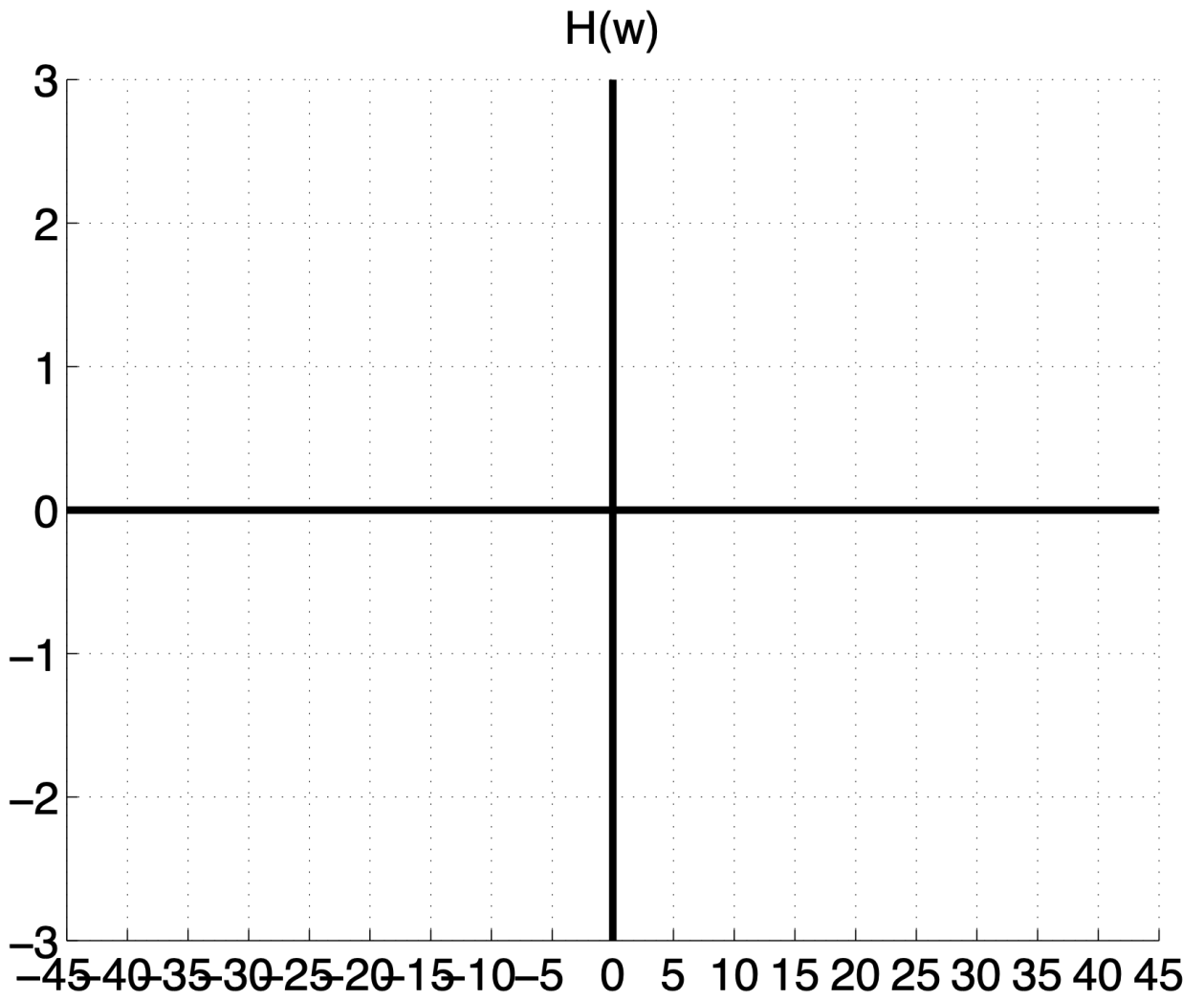

Figure 2: Frequency response of LTI system

(b) (20 points) Consider an LTI system with Frequency response shown below:

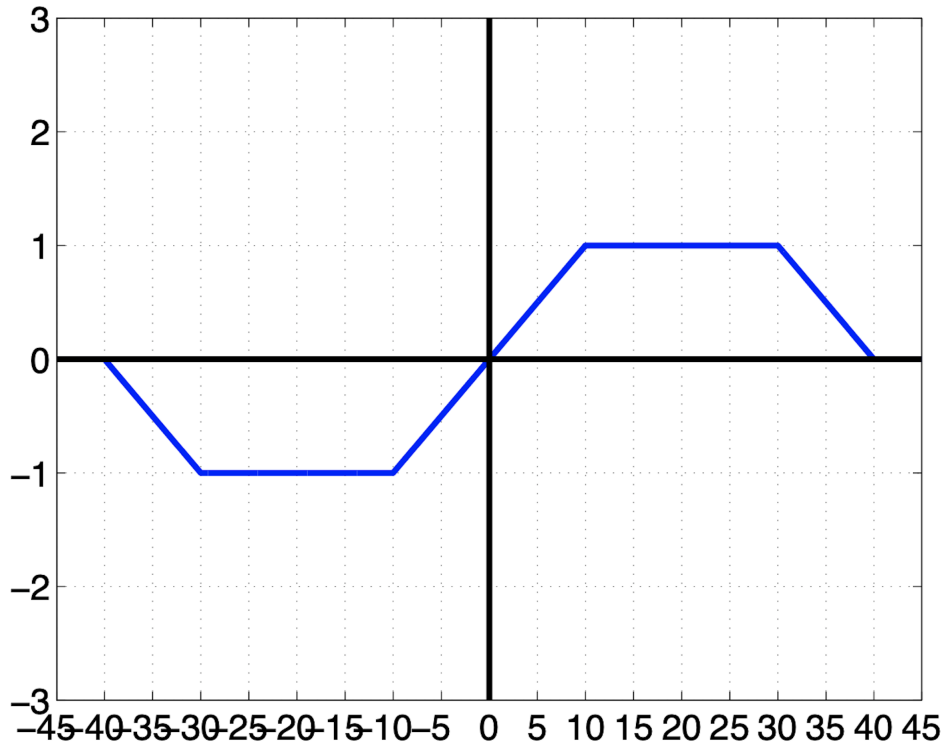

Figure 3: Frequency Response of LTI system

For the LTI system with the frequency response sketched above, determine the output  $y(t)$  for the input  $x(t)$  given below, which is the Fourier Series expansion for a periodic sawtooth waveform with fundamental frequency  $\omega_0 = 5$  rads/sec.

$$x(t) = \sum_{k=-\infty}^{k=\infty} a_k e^{jk5t}$$

where,

$$a_k = \frac{j(-1)^k}{k\pi} \text{ for } k \neq 0, a_0 = 0$$

Show your work and write your expression for  $y(t)$  in the space provided below and on the next page.



### 3. Modulation and demodulation (56 points)

It is given that input signals  $a(t)$  and  $b(t)$  are real and even, with Fourier Transforms shown below.

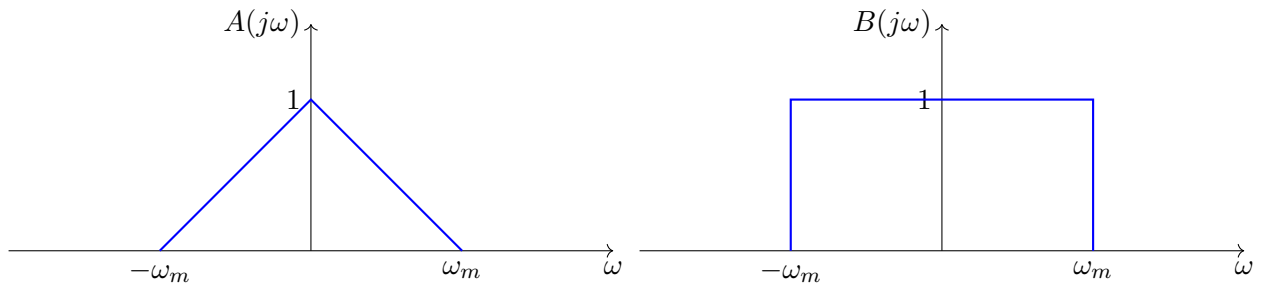

Consider the system below:

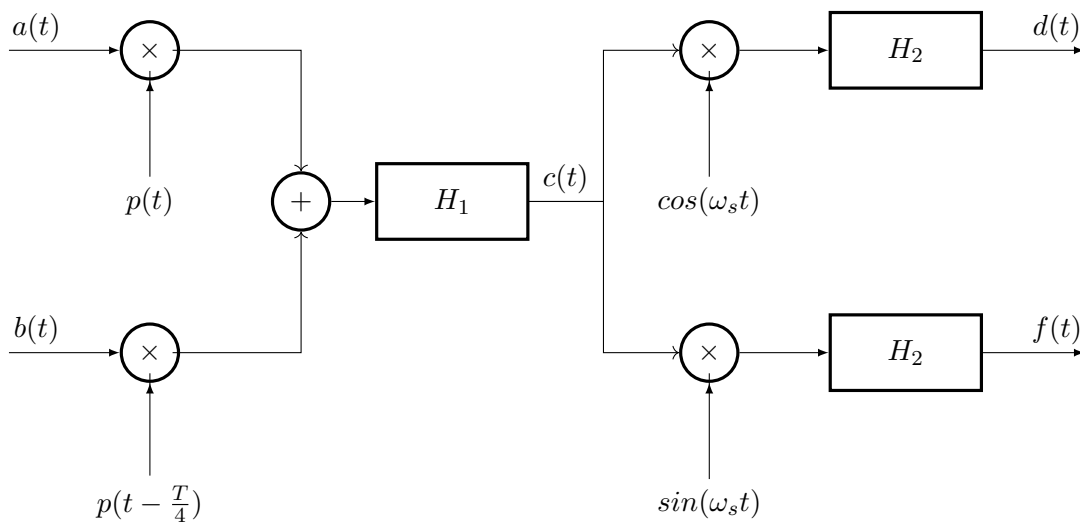

Where we define the following filters with conditions:

$$H_1(j\omega) = \begin{cases} T, & \omega_s - \omega_m \leq |\omega| \leq \omega_s + \omega_m \\ 0, & \text{otherwise.} \end{cases}$$

$$H_2(j\omega) = \begin{cases} 1, & |\omega| \leq \omega_m \\ 0, & \text{otherwise.} \end{cases}$$

$$p(t) = \sum_{-\infty}^{\infty} \delta(t - nT)$$

$$\frac{2\pi}{T} = \omega_s > 2\omega_m$$

**Note:** You are not required to consider amplitude scaling when answering this question.

- (a) (15 points) In lectures, we found the Fourier Transform of the impulse train using the Fourier Series. Using a similar argument, derive the Fourier Transform of the shifted impulse train,  $p(t - \frac{T}{4})$ .

*Hint: Recall  $e^{-j\frac{\pi}{2}} = -j$ . You may need this to simplify your solution.*

- (b) (16 points) Plot the Real and Imaginary components of  $C(j\omega)$  (the Fourier Transform of the output signal of the bandpass filter  $H_1$ ).

(c) (16 points) Plot the Real and Imaginary Components of  $D(j\omega)$  and  $F(j\omega)$ .

(d) (9 points) Describe how  $d(t)$  relates to  $a(t)$  and/or  $b(t)$ .

4. **Laplace Transform** (46 points)

(a) (20 points) Find the Laplace transforms of the following signals and determine their region of convergence.

i.  $f(t) = e^{-at} (\cos(\omega_0 t) - 1) u(t)$

ii.  $f(t) = \int_{0^-}^{t-1} e^{-ax} (\cos(\omega_0 x) - 1) dx, t - 1 \geq 0$



- (b) (10 points) Find the inverse Laplace transform  $f(t)$  for the following  $F(s)$ . ( $f(t)$  is a causal signal.)

$$F(s) = \frac{s^2 + s + 1}{(s + 1)(s + 2)(s + 3)}$$

(c) (16 points) Prove the following statements

i. (8 points) If  $x(t)$  is an even function, so that  $x(t) = x(-t)$ , then  $X(s) = X(-s)$ .

ii. (8 points) If  $x(t)$  is an odd function, so that  $x(t) = -x(-t)$ , then  $X(s) = -X(-s)$ .

**Bonus** (15 points)

This problem is about determining the Fourier Transform of the signal  $x_a(t) = \tan^{-1}(at)$ , working through a sequence of successive steps. Clearly delineate your work and circle your answer for each part below.

1. (10 points) Compute the Fourier transform of

$$x(t) = \tan^{-1}(t)$$

*Hint:* You might find the following calculus result useful

$$\frac{d}{dt} \tan^{-1}(t) = \frac{1}{1+t^2}$$

2. (3 points) Does your answer for part (a) have a real part? Explain how your answer is consistent with the symmetry properties of the Fourier Transform.

3. (2 points) Now use one of the properties of the Fourier Transform to determine the Fourier Transform for the more general case below, where  $a$  is a real-valued positive constant.

$$x_a(t) = \tan^{-1}(at)$$