

Name JAI SRIVASTAV
First Last
Student ID # 604-605-757

University of California
Los Angeles
Computer Science Department

CSM51A/EEM16 Midterm Exam
Winter Quarter 2016
February 8th 2016

This is a closed book exam. Absolutely nothing is permitted except pen, pencil and eraser to write your solutions. Any academic dishonesty will be prosecuted to the full extent permissible by university regulations.

Time allowed 100 minutes.

Problem (possible points)	Points
1 (20)	20
2 (20)	20
3 (20)	20
4 (20)	18
5 (20)	20
Total (100)	98

2

Problem 1 (20 points)

Use only the "E" gate defined below to implement Boolean function:

$$F = w'xy' + wxz + w'x'z + wx'y'z'$$

You may also use constants 0 and 1 as inputs.

a	b	c	E(a,b,c)
0	0	0	0
0	0	1	1
0	1	0	1
0	1 <td>1</td> <td>1</td>	1	1
1	0	0	1
1	0	1	1
1	1	0	1
1	1	1	0



For this problem I will define more traditional gates with the E gate and use the traditional gates in my final solution.

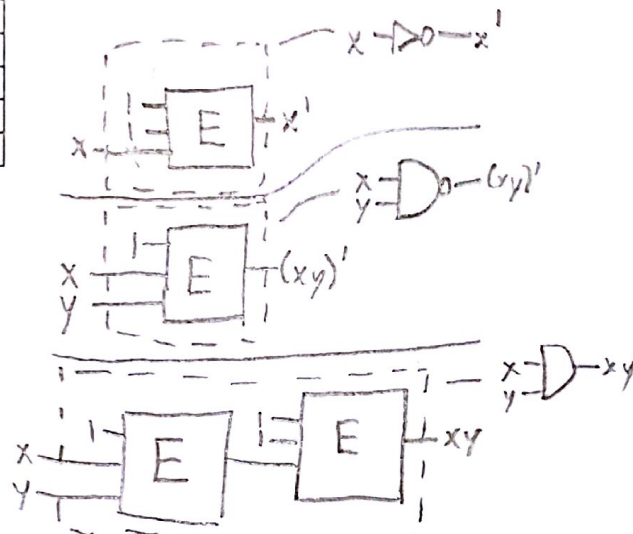

$$(abc)' = ((ab)c)', \quad (abcd)' = (((abc)d)')$$

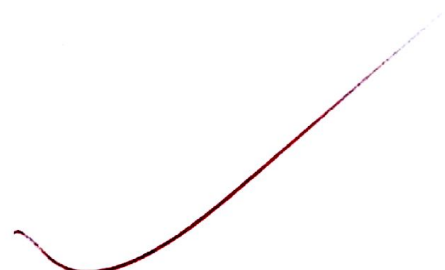
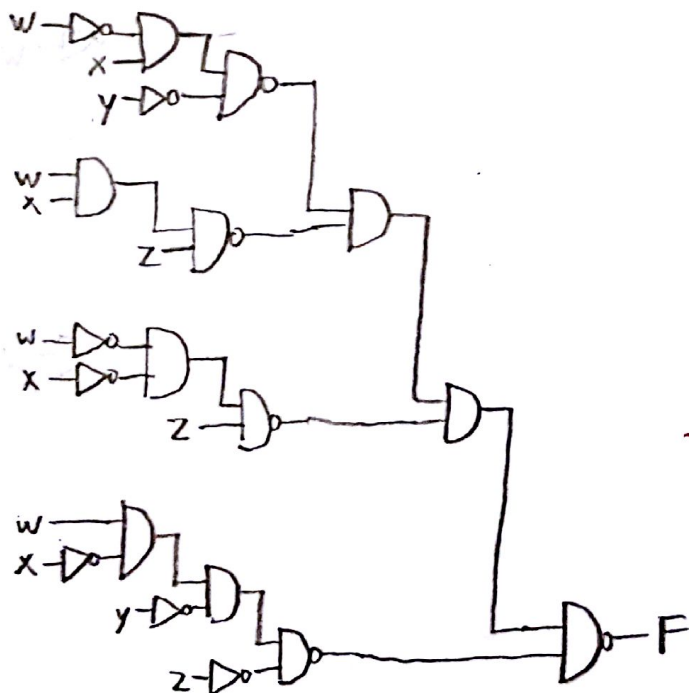

20

Problem 2 (20 points)

Given the network below, calculate the critical path delay. Consider L → H delay when calculating the critical path.

Gate	Fan-in	t_{pLH}	t_{pHL}
AND	2	$0.15 + 0.037L$	$0.16 + 0.017L$
AND	3	$0.20 + 0.038L$	$0.18 + 0.018L$
OR	2	$0.12 + 0.037L$	$0.20 + 0.019L$
OR	3	$0.12 + 0.038L$	$0.34 + 0.022L$

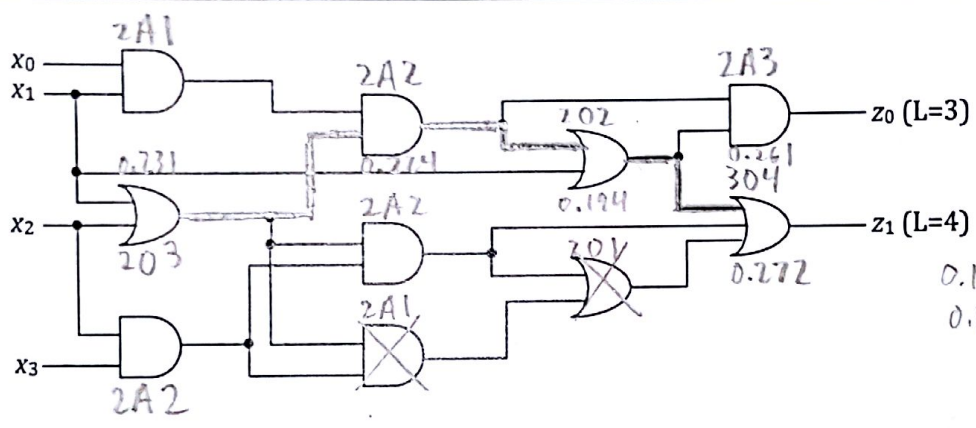

$$\begin{array}{r} 12 \\ 0.037 \\ \hline 1.71 \end{array}$$

$$\begin{array}{r} 13 \\ 0.038 \\ \hline 1.52 \end{array}$$

$$\begin{array}{r} \underline{202} \\ 0.12 + 0.037(2) \\ 0.12 + 0.074 \\ 0.194 \end{array}$$

$$\begin{array}{r} \underline{2A2} \\ 0.15 + 0.037(2) \\ 0.15 + 0.074 \\ 0.224 \end{array}$$

$$\begin{array}{r} \underline{203} \\ 0.12 + 0.037(3) \\ 0.12 + 0.111 \\ 0.231 \end{array}$$

$$\begin{array}{r} \underline{304} \\ 0.12 + 0.038(4) \\ 0.12 + 0.152 \\ 0.272 \\ \hline 0.261 \\ \underline{304} \\ 0.15 + 0.037(3) \\ 0.15 + 0.111 \\ 0.261 \end{array}$$

CRITICAL PATH = $304 + 202 + 2A2 + 203 =$
 $= 0.272 + 0.194 + 0.224 + 0.231 =$
 $= 0.466 + 0.455 =$
 $= \boxed{0.921}$

$$\begin{array}{r} 4.66 \\ 4.55 \\ \hline 9.21 \end{array}$$

20

Problem 3 (20 points)

Four 4-bit numbers A, B, C, and D are given as inputs. $E=A+B$, $F=C+D$. Design a system that outputs the larger number between E and F. If $E=F$, output either E or F. You can use any type of gates to implement your design.

ONE BIT ADDER

X	Y	C_i	Z	C_o
0	0	0	0	0
0	0	1	1	0
0	1	0	1	0
0	1	1	0	1
1	0	0	1	0
1	0	1	0	1
1	1	0	0	1
1	1	1	1	1

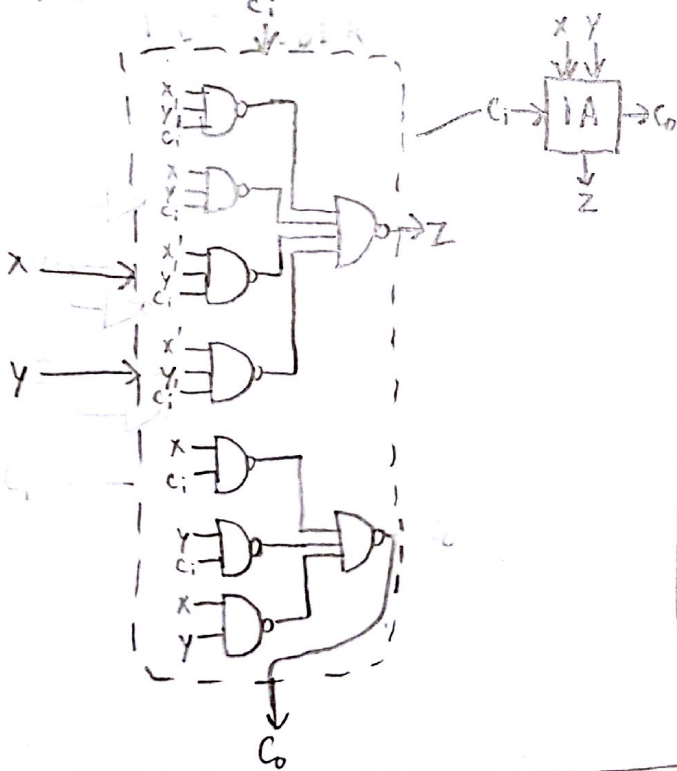
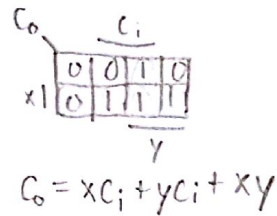
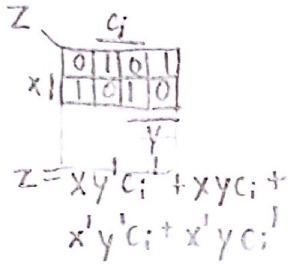

4 BIT ADDER

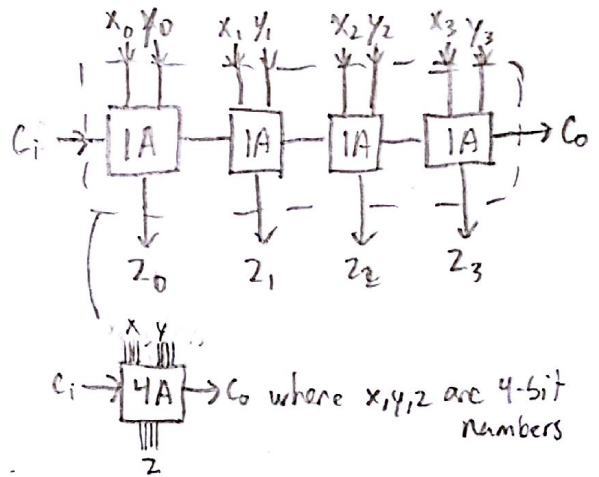

ONE BIT COMPARATOR

X	Y	g_i	g_o
0	0	0	0
0	0	1	0
0	1	0	0
0	1	0	0
1	0	0	0
1	0	1	0
1	1	0	0
1	1	0	0

$g=1$ when $x > y$
 $g=0$ when $x < y$

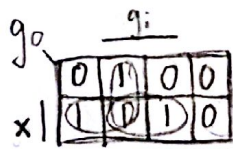

$$g_o = xy' + xg_i + y'y_i$$

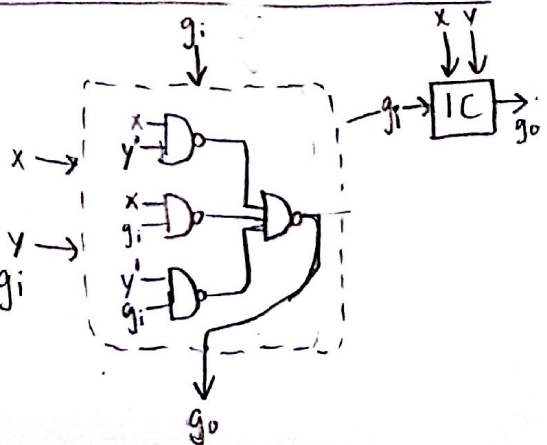

Problem 3) Extra Page

5 BIT COMPARITOR

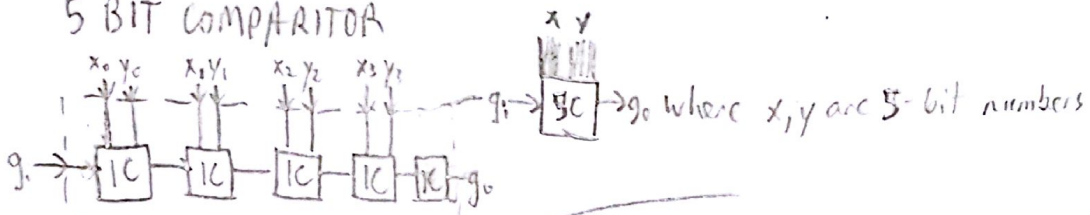

5 BIT SELECTOR

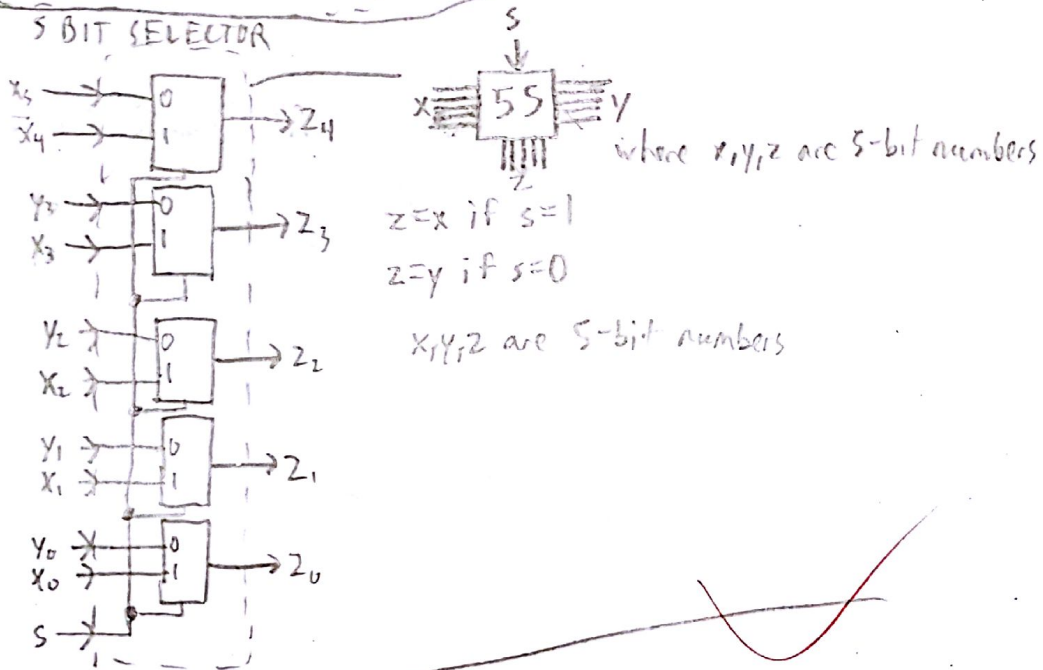

Final Design

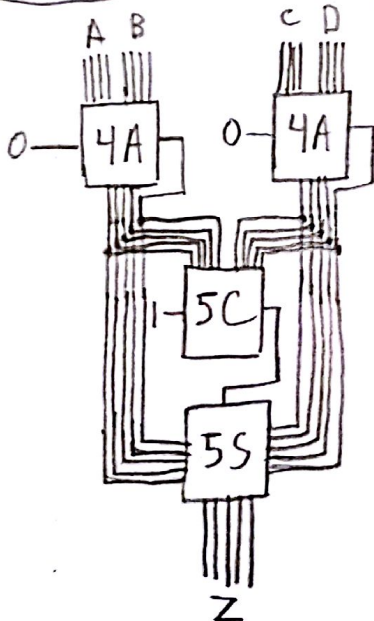

18

Problem 4 (20 points)

For a K-map, M denotes the number of prime implicants of the K-map, and N denotes the number of essential prime implicants of the K-map. Draw a 4×4 K-map that has the largest value of $P=M-N$ among all the 4×4 K-maps.

For example, in the following 4×4 K-map, $M=3$, $N=2$, $P=M-N=1$.

	x_0				
	0	0	0	0	
	1	1	0	0	x_2
x_3	1	1	1	0	
	0	0	1	0	
	x_1				

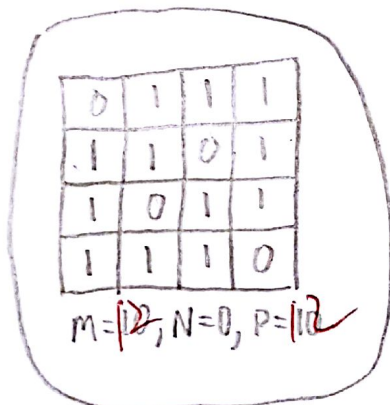
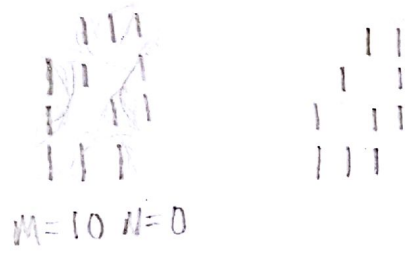

18

22

Problem 5 (20 points)

Use only multiplexers to design a system with input $x \in (0,1,2, \dots, 8)$, outputs y and z that implements the following equation

$$(x)_{10} = (yz)_3$$

In the system, x is encoded as $x_3x_2x_1x_0$ in binary. y is encoded as y_1y_0 in binary, and z is encoded as z_1z_0 in binary.

Note that the outputs y and z represent the two digits of a base-3 number.

For example, if $x=7$ ($x_3x_2x_1x_0=0111$), then the system will solve: $(7)_{10} = (21)_3$. Thus $y = 2$ ($y_1y_0=10$) and $z = 1$ ($z_1z_0=01$).

x_3	x_2	x_1	x_0	y_1	y_0	z_1	z_0
0	0	0	0	0	0	0	0
0	0	0	1	0	0	0	1
0	0	1	0	0	0	1	0
0	0	1	1	0	1	0	0
0	1	0	0	0	1	0	1
0	1	0	1	0	1	1	0
0	1	1	0	1	0	0	0
0	1	1	1	1	0	0	1
1	0	0	0	1	0	1	0
1	0	0	1	1	0	1	1
1	0	1	0	1	1	0	0
1	0	1	1	1	1	0	1
1	1	1	1	1	1	1	0

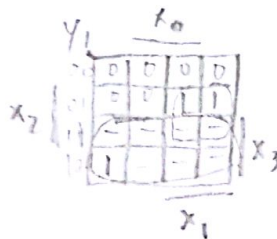

$$y_1 = x_3 + x_2x_1$$

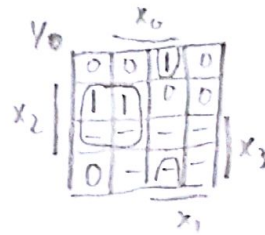

$$y_0 = x_2x_1' + x_2'x_1x_0$$

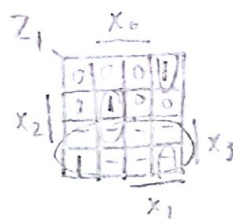

$$z_1 = x_3 + x_2x_1'x_0 + x_2'x_1x_0'$$

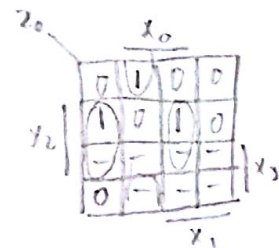

$$z_0 = x_2x_1'x_0' + x_2'x_1x_0 + x_2x_1x_0$$

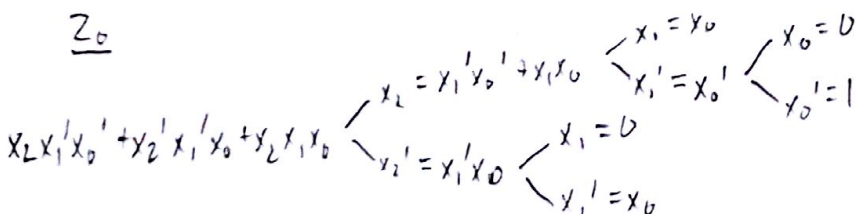
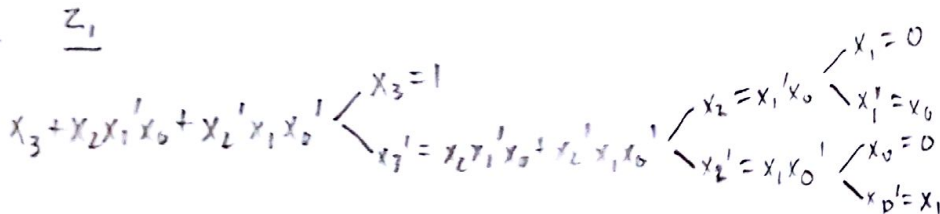
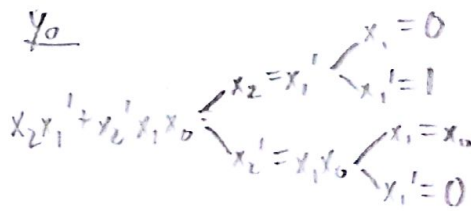
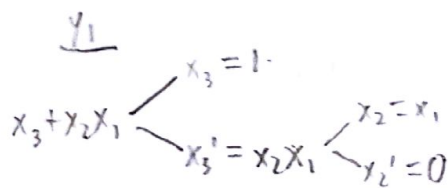

GATE NETWORK ON NEXT PAGE



Problem 5) Extra Page

