

[CS M51A FALL 19] MIDTERM EXAM

Date: 11/5/19

TAs

- The midterm is closed book, and up to 4 sheets of summary notes are allowed.
- Please show all your work and write legibly, otherwise no partial credit will be given.
- This should strictly be your own work; any form of collaboration will be penalized.

Name : Yan Qu

Student ID : 605206804

Problem	Points	Score
1	10	10
2	10	10
3	15	15
4	15	14
5	20	20
6	18	18
7	12	12
Total	100	99

Great job !!

Problem 1 (10 points)

The following questions are based on the function described below. This is a minority function, where the output is 1 when less than half of the inputs are 1.

Inputs: $a, b, c \in \{0, 1\}$

Outputs: $z \in \{0, 1\}$

Function: $z = \begin{cases} 1 & \text{if one or zero inputs are 1,} \\ 0 & \text{otherwise} \end{cases}$

1. (4 points) Complete the given table.

a	b	c	$z = E(a, b, c)$
0	0	0	1
0	0	1	1
0	1	0	1
0	1	1	0
1	0	0	1
1	0	1	0
1	1	0	0
1	1	1	0

(4)

2. (6 points) If the constant input 0 is allowed (but not 1), does this function form a universal set? Is it universal if 1 is allowed but not 0? Show proof.

$$\begin{aligned}
 Z &= a'b'c' + a'b'c + a'bc' + abc' \\
 &= a'b'(c' + c) + a'bc' + abc' \\
 &= a'(b' + bc') + abc' \\
 &= a'(b' + c) + abc' \\
 &= a'b' + a'c' + abc' = a'b' + b'c' + a'b'
 \end{aligned}$$

(2)

Since we know {AND, NOT} and {OR, NOT} are universal sets. If only 0 is allowed, we can tell from both the table and the expression that NOT is not possible. Therefore, if only 0 is allowed, this function does NOT form a universal set.

If 1 is allowed, we can form NOT by $E(x, x, 1) = x'x' + x' \cdot 0 + x \cdot 0 = x'$

and OR by first getting $E(1, x, y) = 0x' + 0y' + 1 \cdot xy' = xy'$

and then NOT it using $E(xy', xy', 1) = (xy')'$
 So it's universal if 1 is allowed (4)

if 0 is allowed \Rightarrow NO
 if 1 is allowed \Rightarrow YES

Problem 2 (10 points)

Given the following simplification of a boolean expression, answer the following.

$$\begin{aligned}
 & (ab' + c')'(b' + c)(a + bc') & (1) \\
 = & (ab')c'(b' + c)(a + bc') & (2) \\
 = & (a' + b)c'(b' + c)(a + bc') & (3) \\
 = & (a' + b)c'(ab + ac + bb'c' + bcc') & (4) \\
 = & (a' + b)c'(ab + ac) & (5) \\
 = & (a' + b)(ab + ac)c' & (6) \\
 = & (aa'b + abb + aa'c + abc)c' & (7) \\
 = & abc' + abcc' & (8) \\
 = & abc' & (9)
 \end{aligned}$$

1. (4 points) There is at least one mistake in this simplification. Find all steps that are derived incorrectly from its previous step (for example, write (8)→(9) if equation (9) is derived incorrectly from (8)).

(1)→(2)

(3)→(4)

u

2. (6 points) Show the correct simplification of (1).

$$\begin{aligned}
 & (ab' + c')'(b' + c)(a + bc') \\
 = & (ab')c'(b' + c)(a + bc') \\
 = & (a' + b)c'(b' + c)(a + bc') \\
 = & (a' + b)c'(ab' + ac + b'bc' + bcc') \quad \because \begin{matrix} aa' = 0 \\ a \cdot 0 = 0 \\ a + 0 = a \end{matrix} \\
 = & (a' + b)c'(ab' + ac) \\
 = & (a'ab' + ab'b + a'ac' + bac)c \\
 = & abc \cdot c \rightarrow \because c \cdot c = c \\
 = & abc
 \end{aligned}$$

b

(10)

Problem 3 (15 points)

Design a two-level gate network of the following system.

Inputs: $x, y \in \{0, 1, 2, 3\}$

Outputs: $z \in \{0, 1, 2, 3\}$

Function: $z = \{3xy + 3\} \text{ mod } 4$

1. (3 points) Complete the switching table using binary encoding for all values.

x_1	x_0	y_1	y_0	z_1	z_0
0	0	0	0	1	1
0	0	0	1	1	1
0	0	1	0	1	1
0	0	1	1	1	1
0	1	0	0	1	1
0	1	0	1	1	0
0	1	1	0	0	1
0	1	1	1	0	0
1	0	0	0	1	1
1	0	0	1	0	1
1	0	1	0	1	1
1	0	1	1	0	1
1	1	0	0	1	1
1	1	0	1	0	0
1	1	1	0	0	1
1	1	1	1	1	0

3

2. (4 points) Show the switching expression of z_1 and z_0 in sum of minterms form.

$$z_1 = \sum m(0, 1, 2, 3, 4, 5, 8, 10, 12, 15)$$

$$z_0 = \sum m(0, 1, 2, 3, 4, 6, 8, 9, 10, 11, 12, 14)$$

4

3. (4 points) Show the switching expression of z_1 and z_0 in product of maxterms form.

$$z_1 = \prod M(6, 7, 9, 11, 13, 14)$$

$$z_0 = \prod M(5, 7, 13, 15)$$

4

4. (4 points) Draw the two-level NAND-NAND or NOR-NOR network for the **canonical** sum of products or product of sums form of z_0 (and not z_1). Assume that complemented inputs are available. Select the two-level network that requires the smaller total number of NAND or NOR gates (do not count NOT gates).

Since we want the smallest number of gates, we would do product of sums since there are only 4 maxterms in z_0 . using a NOR-NOR network

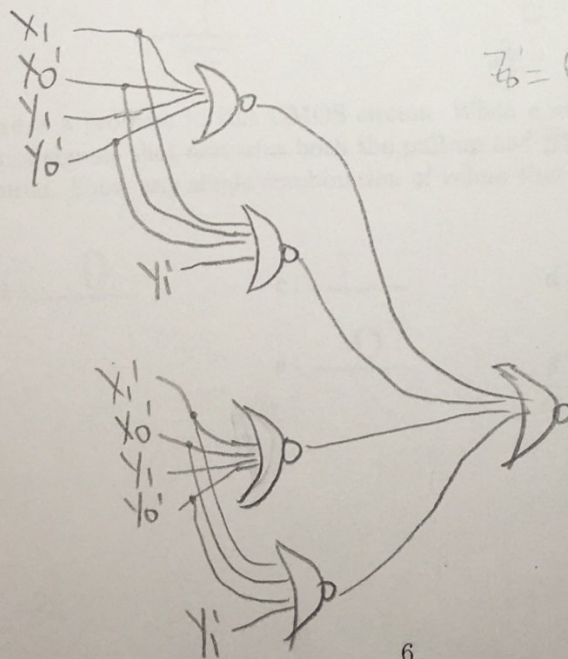

$$z_0 = (x_1 + x_0' + y_1 + y_0') (x_1 + x_0 + y_1' + y_0') (x_1' + x_0 + y_1' + y_0') (x_1' + x_0' + y_1 + y_0')$$

4

15

Problem 4 (15 points)

Answer the following questions about the given CMOS circuit.

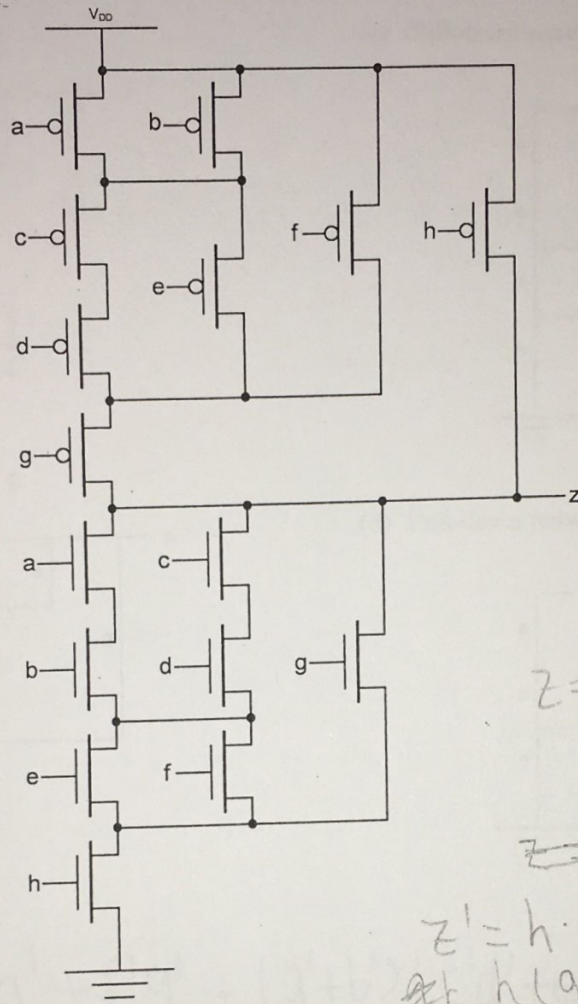

1. (7 points) There is a problem in this CMOS circuit. When $a = 1$, $f = 1$ and $h = 1$, there exists at least one combination of signals that activates both the pull-up and pull-down networks and forms a direct path from V_{DD} to ground. Show any single combination of values that makes this happen.

b: 0

c: 1

d: 1

e: 0

g: 0

7

2. (8 points) Assuming that the pull-up network has the correct functionality that we want, show the expression for the corresponding pull-down network. Which one of the following is the expression equivalent to? (each letter in the diagram stands for an NMOS transistor)

(a) Pull-down network 1

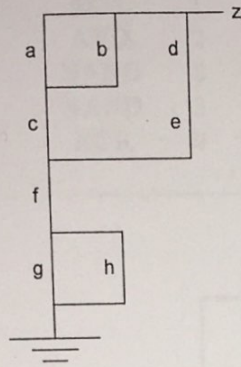

(c) Pull-down network 3

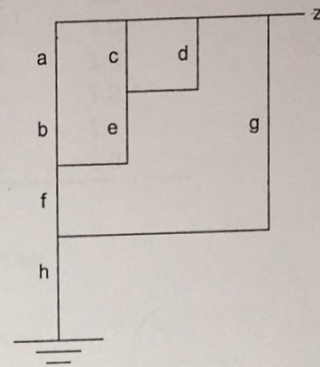

(b) Pull-down network 2

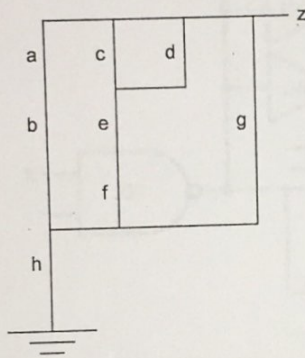

(d) Pull-down network 4

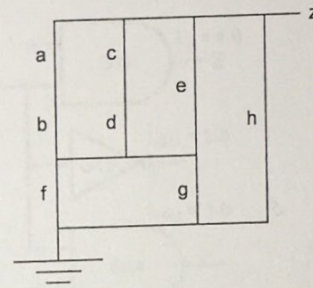

$$\text{pull up: } Z = h' + f'g' + (a'+b')(c'd'+e')g'$$

$$\text{pulldown} = Z' = h \cdot (f'g')' \cdot ((a'+b')(c'd'+e')g')'$$

$$= h(f+g) \cdot ((a'+b)' + ((c'd'+e')g')')$$

$$= h(f+g)(ab + (cd'e) + g)$$

$$= h(f+g)(ab + ((c'd')e) + g)$$

$$= h(f+g)(ab + ((c+d)e) + g)$$

7

8

(c) network 3 is equivalent.

14

Problem 5 (20 points)

Consider the following gate network. The gate characteristics are given in the table below.

Gate Type	Fan-in	Propagation Delays (ns)		Load Factor I
		t_{pLH}	t_{pHL}	
NOT	1	$0.02 + 0.038L$	$0.05 + 0.017L$	1.0
AND	2	$0.15 + 0.037L$	$0.16 + 0.017L$	1.0
NAND	2	$0.05 + 0.038L$	$0.08 + 0.027L$	1.0
NAND	3	$0.07 + 0.038L$	$0.09 + 0.039L$	1.0
XOR	2	$0.30 + 0.036L$	$0.30 + 0.021L$	1.1
		$0.16 + 0.036L$	$0.15 + 0.020L$	2.0

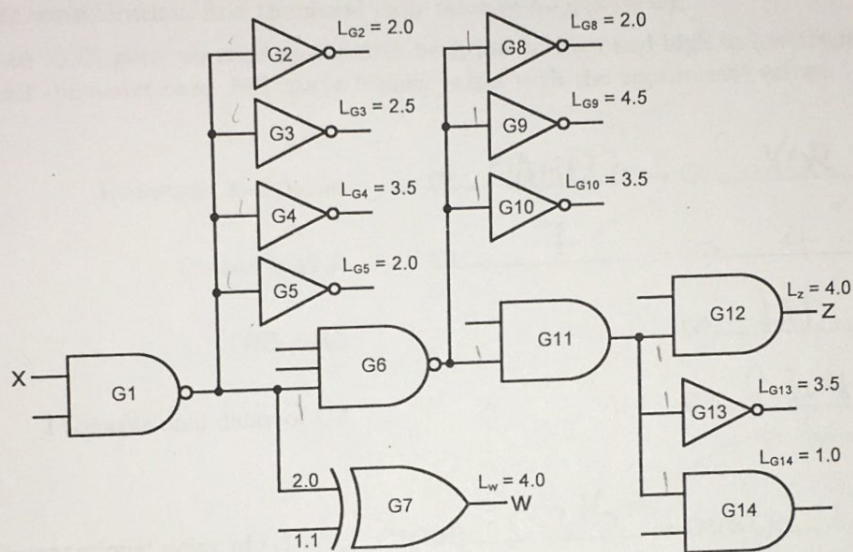

1. (8 points) Determine the propagation delay $t_{pLH}(x \rightarrow z)$. Assume that the unconnected inputs to G1, G6, G11 and G12 have value 1 to allow changes in x to propagate to z . Fill in the blanks below with the appropriate values.

Gate type and fan-in

G1: NAND 2 G6: NAND 3 G11: AND 2 G12: AND 2

LH / HL

G1: HL → G6: LH → G11: LH → G12: LH

Output load L

G1: 7 G6: 4 G11: 3 G12: 4

Propagational delay

G1: 0.269 → G6: 0.222 → G11: 0.261 → G12: 0.298

$t_{pLH}(x \rightarrow z)$

1.05 ns

Sum of all delays

$\begin{array}{r} 316 \\ 222 \\ \hline 538 \\ 261 \\ \hline 799 \\ 298 \\ \hline 1097 \end{array}$	$\begin{array}{r} 27 \\ 47 \\ \hline 9199 \\ 08 \\ \hline 269 \end{array}$	$\begin{array}{r} 38 \\ 24 \\ \hline 316 \\ 47 \\ \hline -269 \\ 47 \end{array}$	$\begin{array}{r} 38 \\ 57 \\ \hline 266 \end{array}$	$\begin{array}{r} 269 \\ 222 \\ \hline 491 \\ 261 \\ \hline 752 \\ 298 \\ \hline 1050 \end{array}$
--	--	--	---	--

2. (8 points) Unlike other gates, a low to high input for an XOR gate can cause the output to transition both from low to high and from high to low, depending on the value of the other input.

x	y	XOR
0	0	0
0	1	1
1	0	1
1	1	0

LH LH

From the table, when $x = 0$, a low to high ($0 \rightarrow 1$) transition at input y will cause the output to move from low to high, but when $x = 1$, the same low to high transition at y will cause the output to move from high to low.

Taking this into consideration, find the worst case value of $t_{pLH}(x \rightarrow w)$.

Because G7 is an XOR gate, we need to consider both low to high and high to low transitions at the output of G1, and select the worst case. Fill in the blanks below with the appropriate values.

Gate type and fan-in G1: NAND 2 → G7: XOR 2

Output load L G1: 7 → G7: 4

LH / HL G7: LH

Propagational delay of G7 G7: 0.304 ns 0.16 36
0.16 to 0.036 * 4 144 144

Propagational delay of G1 G1(LH): 0.316 ns or G1(HL): 0.269 ns
0 1 0.08 to 0.07 * 7
0.65 to 0.08 * 7

8

3. (4 points) What is the worst case value of $t_{pLH}(x \rightarrow w)$?

$$0.316 + 0.304 = 0.620 \text{ ns}$$

4

20

Problem 6 (18 points)

Given $f(x_3, x_2, x_1, x_0) = x_3'x_2'x_1'x_0 + x_3'x_2'x_1x_0 + x_3'x_2x_1x_0' + x_3'x_2x_1x_0 + x_3x_2'x_1'x_0 + x_3x_2'x_1x_0$

1. (4 points) Fill out the following K-map.

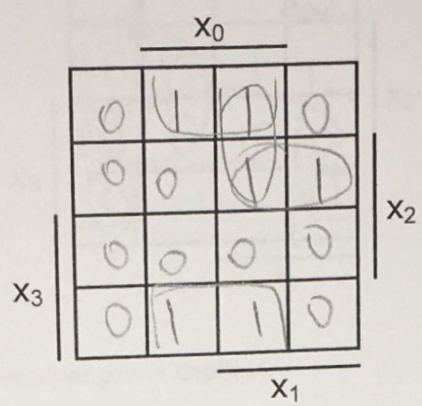

✓ (4)

2. (4 points) Find and circle all the prime implicants. How many implicants are there? Show.

Prime implicants: $x_2'x_0$, $x_3'x_2x_1$, $x_3'x_1x_0$.

Implicants: $x_3'x_2'x_1'x_0$, $x_3'x_2'x_1x_0$, $x_3'x_2x_1x_0'$, $x_3'x_2x_1x_0$

(4)

$x_3x_2'x_1'x_0$, $x_3x_2'x_1x_0$, $x_2'x_0$, $x_3'x_2x_1x_3'x_1x_0$
 $x_2'x_1'x_0$, $x_2'x_1x_0$, $x_3'x_2'x_0$, $x_3'x_2'x_0$

(13)

3. (2 points) Which are the essential prime implicants?

$x_2'x_0$, $x_3'x_2x_1$

✓ (2)

4. (1 point) Write the minimal sum of products expression for f. Is it unique?

$f = x_2'x_0 + x_3'x_2x_1$

(1)

Yes it is unique.

5. (4 points) Find all the prime implicants and show them on the K-map.

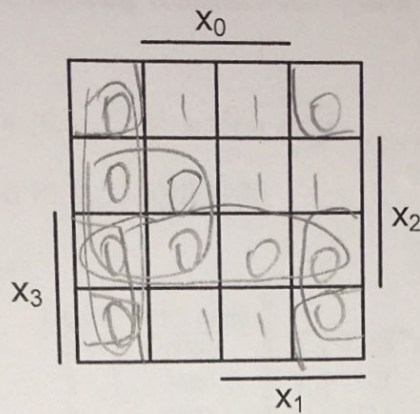

① four corners $X_2 + X_0$

② $X_1 + X_0$

③ $X_3' + X_2'$

④ $X_2' + X_1$

⑤ $X_3' + X_0$

④

6. (2 points) Write down all the essential prime implicants.

$X_2 + X_0$ $X_2' + X_1$ $X_3' + X_2'$

②

7. (1 point) Write the minimal product of sums expression for f . Is it unique?

$f = (X_2 + X_0)(X_2' + X_1)(X_3' + X_2')$ Yes it's unique.

①

18

Problem 7 (12 points)

Obtain the minimal expressions for the following combinational system using K-maps. The system is a Gray code-to-BCD converter.

Input: $x \in \{0, 1, \dots, 9\}$ in Gray code

Output: $z \in \{0, 1, \dots, 9\}$ in BCD

The Gray code table is shown below:

Digit	Gray code		
0	0000	8	1100
1	0001	9	1101
2	0011	10	1111
3	0010	11	1110
4	0110	12	1010
5	0111	13	1011
6	0101	14	1001
7	0100	15	1000

1. (4 points) Complete the binary switching table.

	x_3	x_2	x_1	x_0	z_3	z_2	z_1	z_0
0	00	0	0	0	0	0	0	0
1	10	0	0	1	0	0	0	1
3	20	0	1	0	0	0	1	1
2	30	0	1	1	0	0	1	0
7	40	1	0	0	0	1	1	1
6	50	1	0	1	0	1	1	0
4	60	1	1	0	0	1	0	0
5	70	1	1	1	0	1	0	1
8	1	0	0	0	-	-	-	-
9	1	0	0	1	-	-	-	-
10	1	0	1	0	-	-	-	-
11	1	0	1	1	-	-	-	-
12	1	1	0	0	1	0	0	0
13	1	1	0	1	1	0	0	1
14	1	1	1	0	-	-	-	-
15	1	1	1	1	-	-	-	-

Use '-' to represent don't cares.

4

100

2. (8 points) Use K-maps to find the minimal sum of products expression for each output.

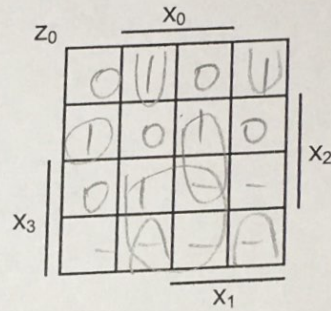
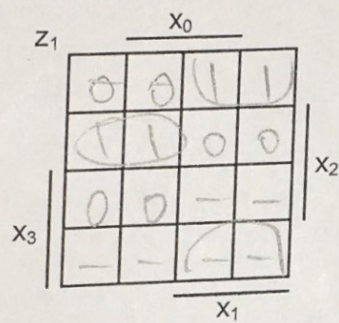
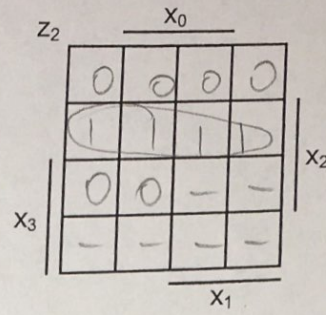
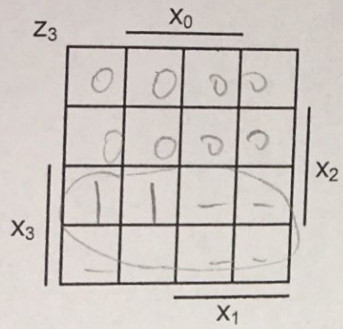

$Z_3 = X_3$ ✓ (2)

$Z_2 = X_3' X_2$ ✓ (2)

$Z_1 = X_2' X_1 + X_3' X_2 X_1'$ ✓ (2)

$Z_0 = X_2' X_1 X_0' + X_3 X_0 + X_2 X_1 X_0 + X_3' X_2 X_1 X_0' + X_2' X_1' X_0$

✓ (2)