

CS M51a / EE M16
Fall 2018
Midterm

Name: _____

UID: _____

Discussion Section (circle): 1A 1B 1C 1D 1E

Problem 1: 20 /20

Problem 2: 20 /20

Problem 3: 16 /20

Problem 4: 16 /20

Problem 5: 20 /20

Total: 92 /100

Read each question carefully before you answer. You have 1 hour and 50 minutes for the exam, which is on average 22 minutes per problem. If you find yourself spending more than 22 minutes on any problem, move on to the next problem and come back to it later. Don't spend the majority of your time on any one problem if there are still other problems to solve, or you may risk running out of time before finishing the exam.

Make sure to show all your work in the space provided on the exam. Points will be taken off for answers without any work. Partial credit will be given where substantial work has been done.

Problem 1 (20 points)

Suppose we want to design a digital clock that displays the current time in hours and minutes as $H_1H_2 : M_1M_2$, such as, for example 12:30, which would set $H_1=1$, $H_2=2$, $M_1=3$, and $M_2=0$.

We will use the standard 12-hour format, so 04:00 can either represent 4am or 4pm (as opposed to the 24-hour military format such as 1600 for 4:00pm).

- a) Determine for each digit (H_1, H_2, M_1, M_2) of the display:
- The range of each digit (i.e. what is the smallest value and the largest value, in decimal)
 - The minimum number of bits necessary to represent each digit in a standard binary format (not BCD)

$$\begin{array}{cccc}
 \text{i.} & H_1 : 0-1 & , & H_2 : 0-9 & , & M_1 : 0-5 & , & M_2 : 0-9 \\
 & \downarrow & & \downarrow & & \downarrow & & \downarrow \\
 \text{ii.} & \underline{1 \text{ bit}} & + & \underline{4 \text{ bits}} & + & \underline{3 \text{ bits}} & + & \underline{4 \text{ bits}} \\
 & & & & & & & \\
 & = & & \underline{12 \text{ bits}} & & & & \text{minimum}
 \end{array}$$

- b) Is the total number of bits for representation the minimum, or is there a more efficient (less number of bits) way to represent the time as a single component (which may need some digit conversion to display the time properly as $H_1H_2 : M_1M_2$)

If there is not a more efficient way to represent the time, explain why not.

If there is a more efficient way, explain why, and what is the minimum total number of bits to represent the time in hours and minutes.

Yes, there's a more efficient way. With digit conversion, every time in the day can be given a minute value. There is 720 minutes (12×60) in standard 12 hr time and $\lceil \log_2(720) \rceil = \boxed{10 \text{ bits}}$ to more efficiently represent it.

Problem 2 (20 points)

Prove or disprove the following equalities, by either constructing the corresponding tables, or using the laws of Boolean Algebra (you do not have to state the name of the law in each step). Note: \oplus represents the XOR function, and \odot represents the XNOR function, $+$ represents the OR function, and \cdot represent the AND function.

a) $((w \oplus x) \cdot (x \oplus y) \cdot (y \oplus z))' = (w \odot x) + (x \odot y) + (y \odot z)$ True

LHS = $(w \oplus x)' + (x \oplus y)' + (y \oplus z)'$ De Morgan's Law
 $= (w \odot x) + (x \odot y) + (y \odot z)$
 $= RHS$

These expressions are equal

w	x	$w \odot x$	$(w \oplus x)'$	$w \oplus x$
0	0	0	1	0
0	1	1	0	1
1	0	1	0	1
1	1	0	1	0

$(w \oplus x)' = w \odot x$

- same for $(x \oplus y)' = x \odot y$

b) $([(w'+x+y)' + (w+x'+y)' + (w+x+y)'] + (w'+x'+y)')' = w' \oplus x' \oplus y'$ True

w	x	y	①	②	③	④	⑤	$w' \oplus x$	⑥ $\oplus y'$
0	0	0	0	0	0	0	0	1	0
0	0	1	0	0	1	0	1	1	1
0	1	0	0	1	0	0	1	0	1
0	1	1	0	0	0	0	0	0	0
1	0	0	1	0	0	0	1	0	1
1	0	1	0	0	0	0	0	1	0
1	1	0	0	0	0	1	0	0	0
1	1	1	0	0	0	1	1	1	1

\therefore These expressions are equal

Problem 3 (20 points)

- a) Analyze the following network by determining the expressions for the outputs (Z_1, Z_0) based on the inputs (A, B, C).
 (Hint: label each gate as a sub-function, T_i , and using a table, determine the result of each sub-function based on its inputs, until you reach the values for Z_1 and Z_0)
DO NOT CALCULATE THE CRITICAL DELAY OF THE NETWORK.

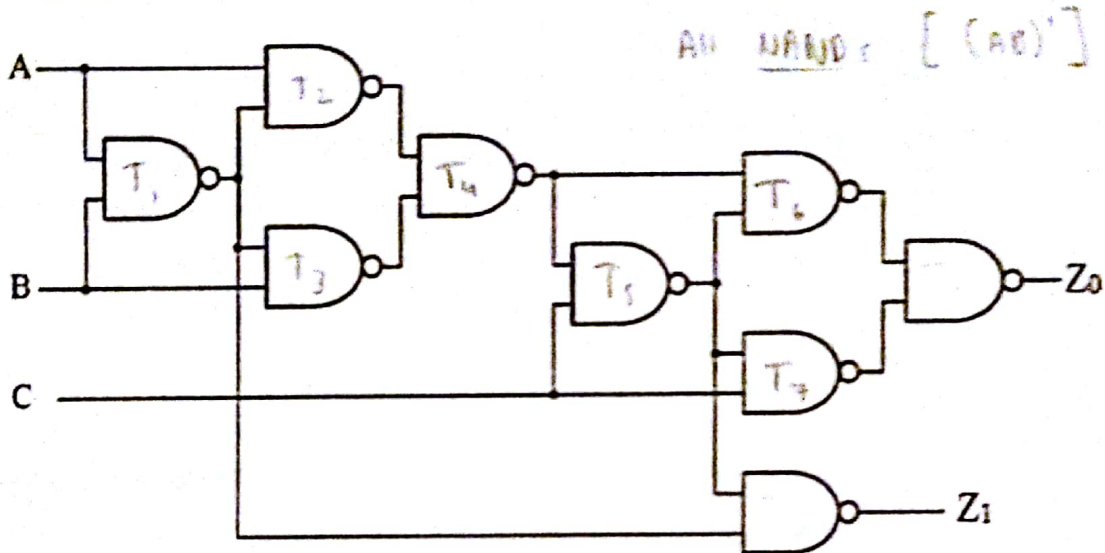

A	B	C	$(AB)'$ T_1	(AB) T_2	$(BC)'$ T_3	(BC) T_4	$(T_3)'$ T_5	$(T_5)'$ T_6	(T_5) T_7	$(T_6)'$ Z_0	$(T_7)'$ Z_1
0	0	0	1	1	1	0	1	1	1	0	0
0	0	1	1	1	1	0	1	1	0	0	1
0	1	0	1	1	0	1	0	0	1	0	1
0	1	1	1	1	0	1	0	1	1	1	0
1	0	0	1	0	1	1	1	0	1	1	0
1	0	1	1	0	1	1	0	1	1	1	0
1	1	0	0	1	1	1	1	1	1	1	0
1	1	1	0	1	1	0	1	1	0	1	1

- b) From a high-level description, what mathematical function is the network performing? Do not state your answer simply as when the output equals 1 such as: " $z_1 = 1$ when $A = \dots$ and $B = \dots$ and $C = \dots$ or when $A = \dots$ and $B = \dots$ and $C = \dots$ ", but give a clear descriptive answer.

$$\begin{aligned}
 Z_1 &= A'BC + AB'C + ABC' + ABC \\
 &= C(A'B + AB') + AB(C + C) \\
 &= C(A \oplus B) + AB
 \end{aligned}$$

$$Z_1 = (A \oplus B)C + AB$$

$$\begin{aligned}
 Z_0 &= A'B'C + A'BC' + ABC' + ABC \\
 &= A'(B'C + BC') + A(B'C + BC) \\
 &= A'(B \oplus C) + A(B \odot C)
 \end{aligned}$$

$$Z_0 = A \oplus B \oplus C$$

Problem 4 (20 points)

00111
01011

- a) Using the 5-input K-map below, find all the prime implicants of the function:
 $f(x_4, x_3, x_2, x_1, x_0) = \Sigma m(7, 11, 13, 14, 15, 19, 21, 22, 23, 25, 26, 27, 28, 29, 30, 31)$

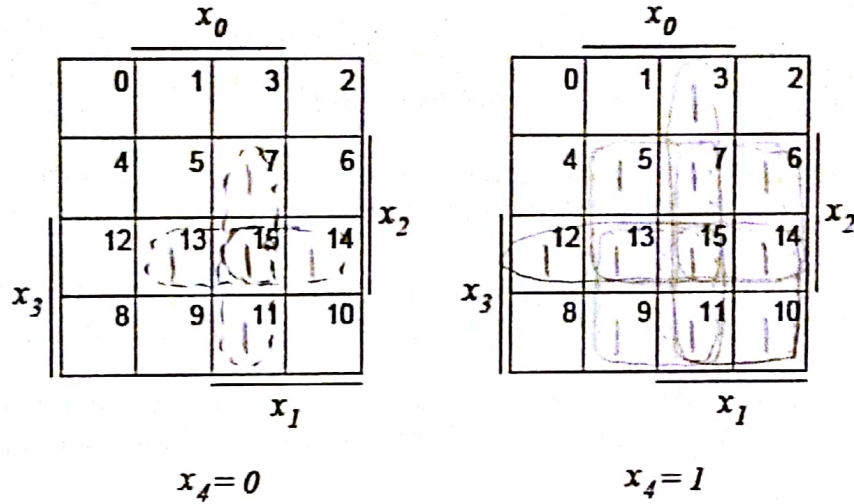

List of Prime implicants:

$x_4 x_2 x_0, x_4 x_2 x_1, x_4 x_3 x_0, x_4 x_3 x_1, x_4 x_3 x_2, x_4 x_1 x_0,$
 $x_3 x_2 x_0, x_3 x_2 x_1, x_3 x_1 x_0, x_2 x_1 x_0$

- b) Which of the prime implicants from part a) are essential?

All 10 prime implicants are essential.

- c) Obtain a minimal sum of products for f .

$$f = x_4 x_2 x_0 + x_4 x_2 x_1 + x_4 x_3 x_0 + x_4 x_3 x_1 + x_4 x_3 x_2 + x_4 x_1 x_0 + x_3 x_2 x_0 + x_3 x_2 x_1 + x_3 x_1 x_0 + x_2 x_1 x_0$$

- d) Describe at a high-level what the function f is determining, i.e. when is $f=1$? Do not merely restate the problem by saying $f=1$ when $x=7$ or $x=11$ or $x=13, \dots$ but give a clear explanation. {Hint: It is a not a complex function, but a common function used when comparing bits}

$$A \oplus B \oplus C \oplus D$$

Problem 5 (20 points)

Using only the PLA below, without adding any rows of extra AND gates, implement a system that represents the following function $z = (z_3, z_2, z_1, z_0)$ given the input $x = (x_3, x_2, x_1, x_0)$, where $0 \leq x \leq 15$, and both x and z are represented in standard binary representation.

$$z = \begin{cases} x & \text{if } x \text{ is a prime number} \\ \lfloor x/2 \rfloor & \text{otherwise} \end{cases}$$

Be sure to label every connection made in the PLA with a dot: • at the appropriate intersection of a horizontal and a vertical line. Do not label unused connections with ×

{Note: $x=0$ and $x=1$ are not prime numbers, and a prime number is only divisible by itself and 1. The notation $\lfloor x/2 \rfloor$ represents the “floor” function of taking the integer part of dividing by 2}.

{Hint: Create a minimal sum-of-products for each output bit of z using either K-maps or laws of Boolean Algebra, and reuse prime implicants for multiple output bits of z }

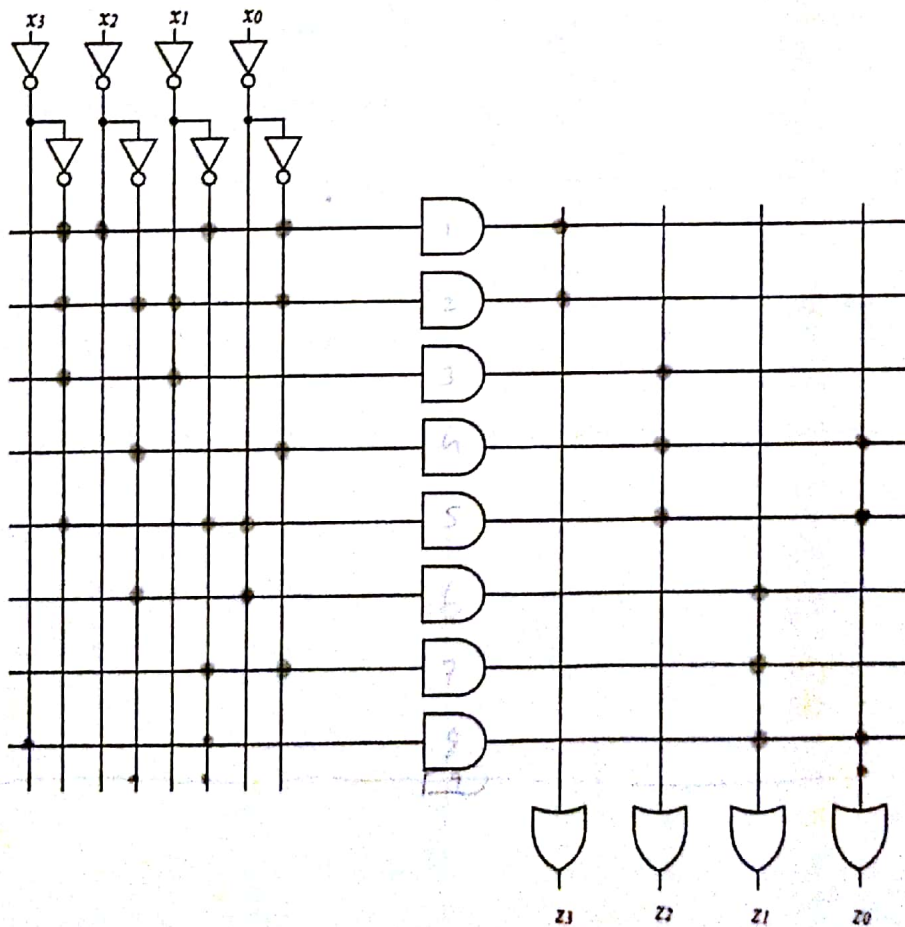

{Space for K-maps to show work for Problem 5, if necessary—the K-maps are optional and will not be graded—they are only for your convenience}

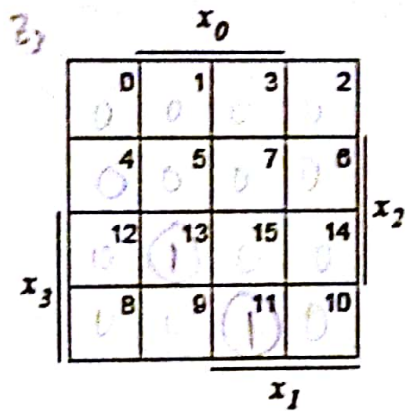

$$Z_3 = x_3 x_2' x_1 x_0 + x_3 x_2 x_1' x_0$$

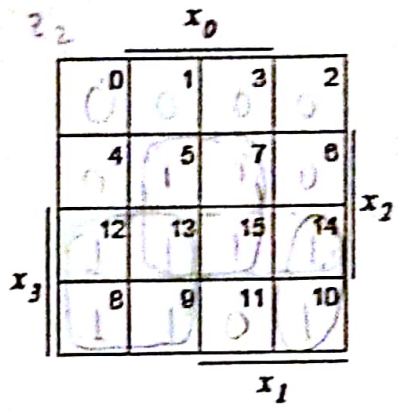

$$Z_2 = x_3 x_1' + x_2 x_0 + x_3 x_1 x_0'$$

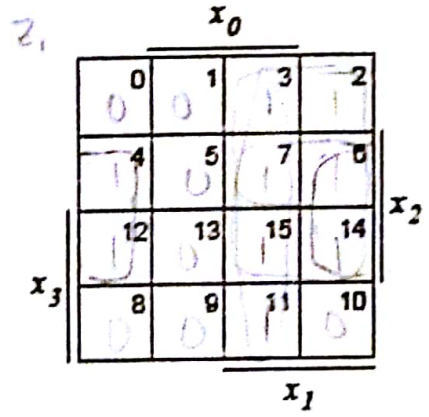

$$Z_1 = x_2 x_0' + x_1 x_0 + x_2' x_1 + x_1 x_1'$$

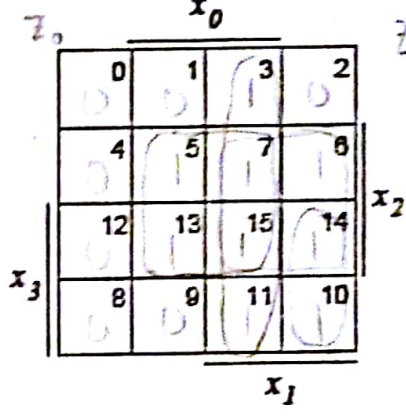

$$Z_0 = x_1 x_0 + x_2 x_0 + x_2 x_1 + x_3 x_1 x_0'$$

$Z = \{x_1, \text{if prime } (x_1, 2), \text{ etc.}\}$

{Space for table to show work for Problem 5, if necessary—the table is optional and will not be graded—it is only for your convenience}

	x_3	x_2	x_1	x_0	Z_3	Z_2	Z_1	Z_0
0	0	0	0	0	0	0	0	0
1	0	0	0	1	0	0	0	0
2	0	0	1	0	0	0	1	0
3	0	0	1	1	0	0	1	1
4	0	1	0	0	0	0	1	0
5	0	1	0	1	0	1	0	1
6	0	1	1	0	0	0	1	1
7	0	1	1	1	0	1	1	1
8	1	0	0	0	0	1	0	0
9	1	0	0	1	0	1	0	0
10	1	0	1	0	0	1	0	0
11	1	0	1	1	0	1	0	0
12	1	1	0	0	0	1	0	0
13	1	1	0	1	0	1	0	0
14	1	1	1	0	0	1	0	0
15	1	1	1	1	0	1	0	0