

Signals and Systems

Midterm Exam Solutions

April 30, 2015

Problem 1 (12 points) We first analyze the properties of the basic blocks. We note that:

- The delay system, block (1), is LTI. To see this, let us consider the system $y(t) = x(t - 1)$. Suppose we have $y_1(t) = x_1(t - 1)$ and $y_2(t) = x_2(t - 1)$. If we have input $ax_1(t) + bx_2(t)$, then the output is $ax_1(t - 1) + bx_2(t - 1) = ay_1(t) + by_2(t)$, implying the linearity of the system. If we have input $x(t - t_0)$, then the output is $x(t - 1 - t_0) = y(t - t_0)$, implying the time-invariance of the system.
- The multiplication system, block (2), is LTI if $a = 0$ and is not LTI if $a \neq 0$. (we suppose $A \neq 0$.) To see this, when $a = 0$, the system becomes $y(t) = Ax(t)$, which is obviously LTI. When $a \neq 0$, we have $y(t) = Ae^{at}x(t)$. Then the output corresponding to the input $x(t - t_0)$ is $Ae^{at}x(t - t_0)$; however, the shifted output is $y(t - t_0) = Ae^{a(t-t_0)}x(t - t_0)$. So the system is not LTI when $a \neq 0$.
- The integral system, block (3), is LTI. Suppose we have $y_1(t) = \int_{-\infty}^t x_1(\tau)d\tau$ and $y_2(t) = \int_{-\infty}^t x_2(\tau)d\tau$. If we have input $ax_1(t) + bx_2(t)$, then the output is $\int_{-\infty}^t [ax_1(\tau) + bx_2(\tau)]d\tau = ay_1(t) + by_2(t)$, implying the linearity of the system. If we have input $x(t - t_0)$, then the output is $\int_{-\infty}^t x(\tau - t_0)d\tau = \int_{-\infty}^{t-t_0} x(\lambda)d\lambda = y(t - t_0)$ (by setting $\lambda = \tau - t_0$), implying the time-invariance of the system.

Next, we have the following two properties of the overall system:

- The interconnection of LTI systems is still an LTI system. We consider the cascade connection and the parallel connection. If we have two LTI systems with impulse response $h_1(t)$ and $h_2(t)$, then the impulse response of the parallel connection is $h_1(t) + h_2(t)$ and the impulse response of the cascade connection of these two systems is $h_1(t) \star h_2(t) = h_2(t) \star h_1(t)$. This means that if we exchange the order of cascade connection of two LTI systems, then we have the same system.

- The interconnection of non-LTI systems may be or may not be an LTI system. For example, the system $y(t) = e^{(t-1)}e^{-t}x(t-1) = e^{-1}x(t-1)$ is an LTI system, which is a concatenation of a multiplication $x(t)e^t$, a delay $x(t-1)e^{t-1}$ and another multiplication $y(t) = x(t-1)e^{t-1}e^{-t}$. In this case, we cannot exchange the order of the blocks. If we exchange the first two blocks, then the system becomes $y(t) = x(t-1)e^te^{-t} = x(t-1)$, which is a different system.

Hence, we have two methods to do this problem.

Method 1 is that you know the system equation of the input and output, then you connect each operation blocks to get the system.

Method 2 is that you know the LTI system impulse response $h(t)$, then you use the property that $h(t)$ is the response of the input $\delta(t)$, by assuming that the input is $\delta(t)$, and the output is $h(t)$. However, if you use method 2, you need to pay attention that the built system should be an LTI system if you are using non-LTI blocks. To sum up, two conditions need to be satisfied: (1) the overall system should be an LTI system; and (2) the output is $h(t)$ when you have the input $\delta(t)$. Then the system can be represented by $y(t) = x(t) \star h(t)$.

- (a) We build this system using method 1, because we know the system function $y(t) = T\{x(t)\}$. The system is shown in Fig.1 (a). The system is not time invariant, because if the input is $x(t - t_0)$, the output is

$$\begin{aligned} 2x(t - t_0 - 3) + \int_{-\infty}^{t-1} 3e^{2\tau}x(\tau - t_0) d\tau \\ = 2x(t - t_0 - 3) + \int_{-\infty}^{t-t_0-1} 3e^{2(v+t_0)}x(v) dv, \end{aligned}$$

but,

$$y(t - t_0) = 2x(t - t_0 - 3) + \int_{-\infty}^{t-t_0-1} 3e^{2v}x(v) dv.$$

- (b) We use the second method to build this system. We first have

$$\begin{aligned} h_1(t) &= 3\delta(t - 2) + 5[u(t) - u(t - 1)] \\ &= 3\delta(t - 2) + 5\left[\int_{-\infty}^t \delta(\tau) d\tau - \int_{-\infty}^{t-1} \delta(\tau) d\tau\right] \end{aligned}$$

The system then can be shown in Fig.1 (b). Here, because all the blocks we are using are LTI blocks, the overall system is LTI. Also, the response to the input $\delta(t)$ is $h_1(t)$. Then our system impulse response is $h_1(t)$. The system is causal, since $h_1(t) = 0$ for $t < 0$.

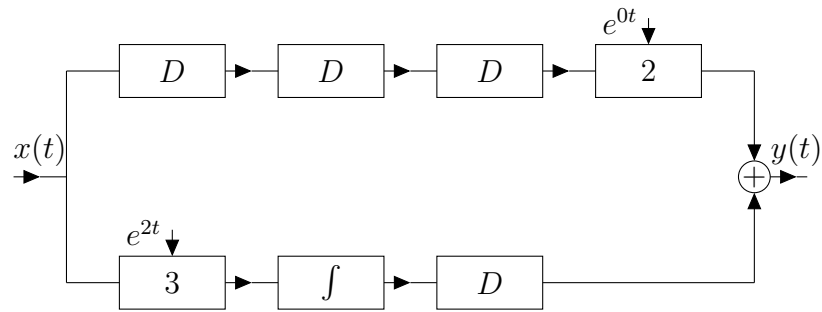

(a) System a

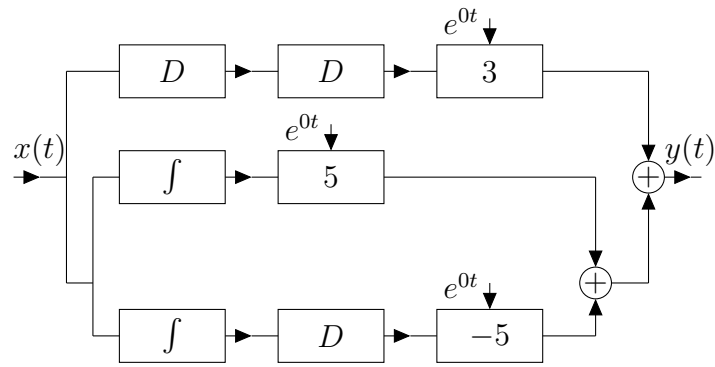

(b) System b

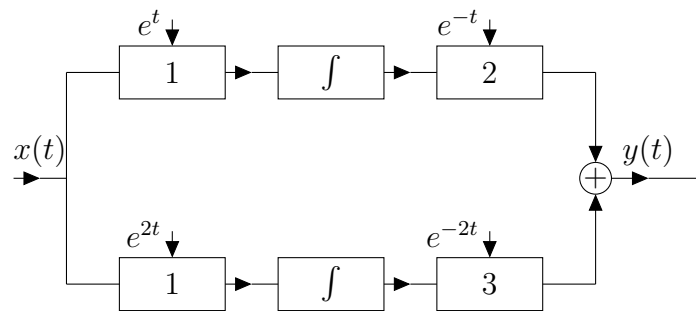

(c) System c

Figure 1: Systems consisting of basic blocks

(c) We first calculate the inverse Laplace transform to get $h_2(t)$:

$$H_2(s) = \frac{5s + 7}{(s + 1)(s + 2)} = \frac{2}{s + 1} + \frac{3}{s + 2};$$

$$h_2(t) = \mathcal{L}^{-1}\{H_2(s)\} = (2e^{-t} + 3e^{-2t})u(t).$$

Here we can use two methods to build the system.

Method 1: we calculate the relationship of the input and output:

$$y(t) = x(t) \star h_2(t) = \int_{-\infty}^{\infty} x(\tau)[2e^{-(t-\tau)} + 3e^{-2(t-\tau)}]u(t - \tau) d\tau$$

$$= \int_{-\infty}^t x(\tau)[2e^{-(t-\tau)} + 3e^{-2(t-\tau)}] d\tau$$

$$= 2e^{-t} \int_{-\infty}^t x(\tau)e^{\tau} d\tau + 3e^{-2t} \int_{-\infty}^t x(\tau)e^{2\tau} d\tau.$$

Method 2: we use the impulse response $h_2(t)$. Here you need to be careful, because if you only consider $h_2(t) = (2e^{-t} + 3e^{-2t}) \int_{-\infty}^t \delta(\tau) d\tau$, and you get an integral and a multiplication, then the system becomes $y(t) = (2e^{-t} + 3e^{-2t}) \int_{-\infty}^t x(\tau) d\tau$, which is not an LTI system. To use this method, you need to write the system impulse response as $h_2(t) = (2e^{-t} \int_{-\infty}^t \delta(\tau)e^{\tau} d\tau + 3e^{-2t} \int_{-\infty}^t \delta(\tau)e^{2\tau} d\tau)$, then the system becomes an LTI system: $y(t) = \int_{-\infty}^t [2e^{-(t-\tau)} + 3e^{-2(t-\tau)}]x(\tau) d\tau$.

Two methods achieve the same system diagram, as shown in Fig.1 (c). The system is stable, because the integral $\int_{-\infty}^{\infty} |h_2(t)| dt = \int_0^{\infty} (2e^{-t} + 3e^{-2t}) dt = 2 + 3/2 = 3.5$ converges.

Problem 2 (10 points)

(a) The signal x_1 is neither odd or even. The “even part” of x_1 can be calculated using the even decomposition:

$$x_e = \frac{x(t) + x(-t)}{2} = \frac{u(t - 1) + u(-t - 1)}{2}$$

(b) To simplify the $u(f(t))$ function, we directly use the definition of the $u(t)$ function:

$$u(f(t)) = \begin{cases} 1, & f(t) \geq 0 \\ 0, & f(t) < 0 \end{cases}$$

Then we have the following expressions:

$$u(2t - 3 - 2) = \begin{cases} 1, & 2t - 3 - 2 \geq 0 \\ 0, & 2t - 3 - 2 < 0 \end{cases} = \begin{cases} 1, & t \geq 2.5 \\ 0, & t < 2.5 \end{cases} = u(t - 2.5)$$

We have

$$\begin{aligned} x_1(t) \star x_2(2t - 3) &= u(t - 1) \star u(2t - 3 - 2) = u(t - 1) \star u(t - 2.5) \\ &= \int_{-\infty}^{\infty} u(\tau - 1)u((t - \tau) - 2.5)d\tau \end{aligned}$$

Then, we simplify the function inside the integral:

$$u(\tau - 1)u((t - \tau) - 2.5) = \begin{cases} 1, & \tau - 1 \geq 0 \text{ and } (t - \tau) - 2.5 \geq 0 \\ 0, & \tau - 1 < 0 \text{ or } (t - \tau) - 2.5 < 0 \end{cases}$$

Case 1: $t \geq 3.5$, we have

$$u(\tau - 1)u((t - \tau) - 2.5) = \begin{cases} 1, & 1 \leq \tau \leq t - 2.5 \\ 0, & \text{otherwise} \end{cases}$$

Case 2: $t < 3.5$, we have

$$u(\tau - 1)u((t - \tau) - 2.5) = 0.$$

Then, the convolution equals:

$$x_1(t) \star x_2(2t - 3) = \begin{cases} \int_1^{t-2.5} 1d\tau = t - 3.5, & t - 3.5 \geq 0 \\ 0, & t - 3.5 < 0 \end{cases} = (t - 3.5)u(t - 3.5).$$

(c) Use the same method as (b) to simplify the $u(f(t))$ function:

$$u(2t - 1) = \begin{cases} 1, & 2t - 1 \geq 0 \\ 0, & 2t - 1 < 0 \end{cases} = \begin{cases} 1, & t \geq 0.5 \\ 0, & t < 0.5 \end{cases} = u(t - 0.5)$$

Let $y(t) = x_1(2t) \star [x_2(-t)e^t]$, then we have

$$y(t) = u(2t - 1) \star [u(-t - 2)e^t] = u(t - 0.5) \star [u(-t - 2)e^t] = \int_{-\infty}^{\infty} u(-\tau - 2)e^\tau u(t - \tau - 0.5)d\tau$$

Then, we simplify the function inside the integral:

$$\begin{aligned} u(-\tau - 2)e^\tau u(t - \tau - 0.5) &= \begin{cases} e^\tau, & -\tau - 2 \geq 0 \text{ and } (t - \tau) - 0.5 \geq 0 \\ 0, & -\tau - 2 < 0 \text{ or } (t - \tau) - 0.5 < 0 \end{cases} \\ &= \begin{cases} e^\tau, & \tau \leq \min\{-2, t - 0.5\} \\ 0, & \tau > \min\{-2, t - 0.5\} \end{cases} \end{aligned}$$

Case 1: $t \geq -1.5$, we have

$$u(-\tau - 2)e^\tau u(t - \tau - 0.5) = \begin{cases} e^\tau, & \tau \leq -2 \\ 0, & \text{otherwise} \end{cases}$$

Case 2: $t < -1.5$, we have

$$u(-\tau - 2)e^\tau u(t - \tau - 0.5) = \begin{cases} e^\tau, & \tau \leq t - 0.5 \\ 0, & \text{otherwise} \end{cases}$$

Therefore, we have the result:

$$y(t) = \begin{cases} \int_{-\infty}^{-2} e^\tau d\tau = e^{-2}, & t \geq -1.5 \\ \int_{-\infty}^{t-0.5} e^\tau d\tau = e^{t-0.5}, & t < -1.5 \end{cases}$$

Figure 2 shows the procedure doing the convolution:

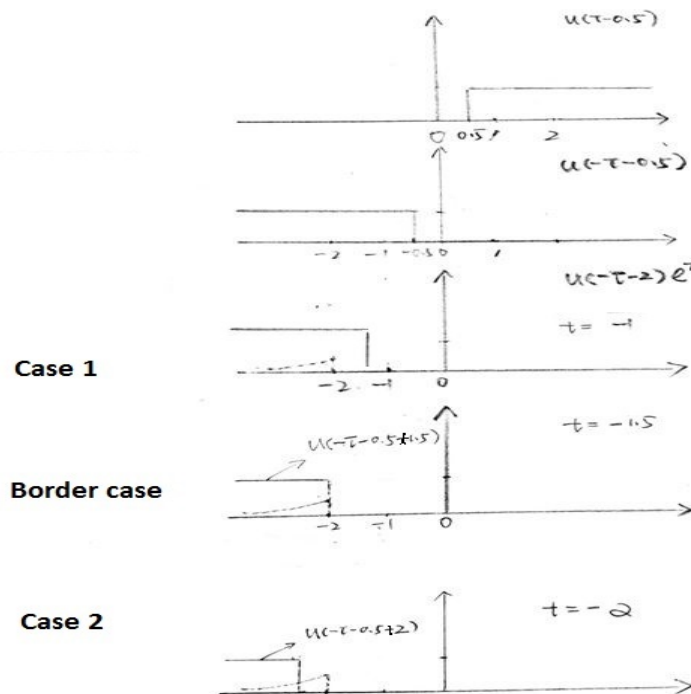

Figure 2: Problem 2c

Problem 3 (6 points)

- (a) The impulse response of the system is denoted as $h(t)$ and the Laplace transform of $h(t)$ is denoted as $H(s)$.

Since $x(t) \star h(t) = y(t)$ and taking the Laplace transform in both sides, we get $X(s)H(s) = Y(s)$, and

$$H(s) = \frac{Y(s)}{X(s)}$$

We have:

$$X(s) = \mathcal{L}\{x(t)\} = \frac{2}{s}$$

$$Y(s) = \mathcal{L}\{y(t)\} = \mathcal{L}\{(t-2)u(t-3)\} = \mathcal{L}\{(t-3)u(t-3) + u(t-3)\} = \frac{e^{-3s}}{s^2} + \frac{e^{-3s}}{s}$$

Therefore,

$$H(s) = \frac{Y(s)}{X(s)} = \frac{(1 + \frac{1}{s})e^{-3s}}{2}$$

Taking the inverse Laplace transform:

$$h(t) = \mathcal{L}^{-1}\left\{\frac{1}{2}e^{-3s} + \frac{1}{2s}e^{-3s}\right\} = \frac{1}{2}\delta(t-3) + \frac{1}{2}u(t-3)$$

- (b) Since we have the response to $x(t) = 2u(t)$, we have $y(t) = \int_{-\infty}^{\infty} x(t-\tau)h(\tau)d\tau = 2 \int_{-\infty}^{\infty} u(t-\tau)h(\tau)d\tau = 2 \int_{-\infty}^t h(\tau)d\tau$. Then by taking derivatives on both sides, we get

$$y'(t) = 2h(t)$$

Thus, we have the impulse response:

$$\begin{aligned} h(t) &= \frac{1}{2} \frac{dy(t)}{dt} \\ &= \frac{1}{2} [u(t-3) + t\delta(t-3) - 2\delta(t-3)] \\ &= \frac{1}{2} [u(t-3) + 3\delta(t-3) - 2\delta(t-3)] \\ &= \frac{1}{2} [u(t-3) + \delta(t-3)]. \end{aligned}$$

Total: 28 points

Signals and Systems

Midterm Exam

12:00 pm - 1:55 pm, April 30, 2015

NAME: _____ UID: _____

This exam has 3 problems, for a total of 28 points.

Closed book. No calculators. No electronic devices.

One page, letter-size, one-side cheat-sheet allowed.

Answer the questions in the spaces provided on the question sheets. If you run out of room for an answer, continue on the back of the page.

Please, write your name and UID on the top of each loose sheet!

GOOD LUCK!

Problem	Points
1	
2	
3	
Total	

A list of Laplace transform pairs and the properties

Type	$f(t)$ ($t > 0^-$)	$F(s)$
(impulse)	$\delta(t)$	1
(step)	$u(t)$	$\frac{1}{s}$
(ramp)	t	$\frac{1}{s^2}$
(exponential)	e^{-at}	$\frac{1}{s+a}$
(sine)	$\sin \omega t$	$\frac{\omega}{s^2 + \omega^2}$
(cosine)	$\cos \omega t$	$\frac{s}{s^2 + \omega^2}$
(damped ramp)	te^{-at}	$\frac{1}{(s+a)^2}$
(damped sine)	$e^{-at} \sin \omega t$	$\frac{\omega}{(s+a)^2 + \omega^2}$
(damped cosine)	$e^{-at} \cos \omega t$	$\frac{s+a}{(s+a)^2 + \omega^2}$

TABLE 12.2 An Abbreviated List of Operational Transforms

Operation	$f(t)$	$F(s)$
Multiplication by a constant	$Kf(t)$	$KF(s)$
Addition/subtraction	$f_1(t) + f_2(t) - f_3(t) + \dots$	$F_1(s) + F_2(s) - F_3(s) + \dots$
First derivative (time)	$\frac{df(t)}{dt}$	$sF(s) - f(0^-)$
Second derivative (time)	$\frac{d^2f(t)}{dt^2}$	$s^2F(s) - sf(0^-) - \frac{df(0^-)}{dt}$
n th derivative (time)	$\frac{d^n f(t)}{dt^n}$	$s^n F(s) - s^{n-1}f(0^-) - s^{n-2}\frac{df(0^-)}{dt} - s^{n-3}\frac{d^2f(0^-)}{dt^2} - \dots - \frac{d^{n-1}f(0^-)}{dt^{n-1}}$
Time integral	$\int_0^t f(x) dx$	$\frac{F(s)}{s}$
Translation in time	$f(t-a)u(t-a), a > 0$	$e^{-as}F(s)$
Translation in frequency	$e^{-at}f(t)$	$F(s+a)$
Scale changing	$f(at), a > 0$	$\frac{1}{a}F\left(\frac{s}{a}\right)$
First derivative (s)	$tf(t)$	$-\frac{dF(s)}{ds}$
n th derivative (s)	$t^n f(t)$	$(-1)^n \frac{d^n F(s)}{ds^n}$
s integral	$\frac{f(t)}{t}$	$\int_s^\infty F(u) du$

TABLE 12.3 Four Useful Transform Pairs

Pair Number	Nature of Roots	$F(s)$	$f(t)$
1	Distinct real	$\frac{K}{s+a}$	$Ke^{-at}u(t)$
2	Repeated real	$\frac{K}{(s+a)^2}$	$Kte^{-at}u(t)$
3	Distinct complex	$\frac{K}{s+\alpha-j\beta} + \frac{K^*}{s+\alpha+j\beta}$	$2 K e^{-\alpha t} \cos(\beta t + \theta)u(t)$
4	Repeated complex	$\frac{K}{(s+\alpha-j\beta)^2} + \frac{K^*}{(s+\alpha+j\beta)^2}$	$2t K e^{-\alpha t} \cos(\beta t + \theta)u(t)$

Note: In pairs 1 and 2, K is a real quantity, whereas in pairs 3 and 4, K is the complex quantity $|K| \angle \theta$.

Problem 1 (12 points) In this problem, we use a set of blocks that can perform basic functions to build more complicated desired systems. Basic systems/connections are given as follows. Note that some of these systems have two inputs and one output.

- (1) A system that delays the input by one unit, i.e., when the input is $x(t)$, the output is $y(t) = x(t - 1)$, as in Fig. 1 (1).
- (2) A system that performs multiplication with Ae^{at} (parameters A and a are arbitrary real numbers that you can select), i.e., when the input is $x(t)$, the output is $y(t) = Ae^{at}x(t)$, as in Fig. 1 (2).
- (3) A system that performs integration, i.e., when the input is $x(t)$, the output is $y(t) = \int_{-\infty}^t x(\tau) d\tau$, as in Fig. 1 (3).
- (4) An addition, i.e., when the input is $x_1(t)$ and $x_2(t)$, the output is $y(t) = x_1(t) + x_2(t)$, as in Fig. 1 (4).

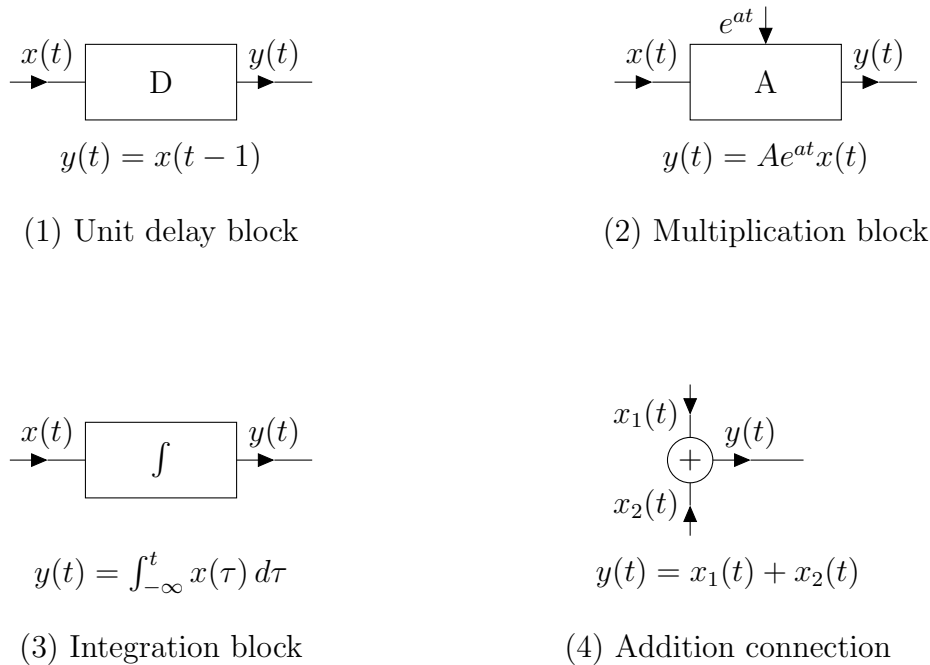

Figure 1: Basic blocks

Suppose you can use as many basic blocks as you want of each basic function. Connect these basic blocks to create systems that can perform the following functions, as shown in Fig. 2:

(a) (4 points) A system that implements the input-output equation:

$$y(t) = 2x(t - 3) + \int_{-\infty}^{t-1} 3e^{2\tau} x(\tau) d\tau$$

Is this system time invariant?

(b) (4 points) A system that implements an LTI system with impulse response:

$$h_1(t) = 3\delta(t - 2) + 5[u(t) - u(t - 1)].$$

Is this system causal?

(c) (4 points) A system that implements a causal LTI system with transfer function

$$H_2(s) = \frac{5s + 7}{(s + 1)(s + 2)}.$$

Is this system stable?

You need to clearly draw the blocks and their interconnections, as well as clearly denote the parameters a and A selected for each block you use.

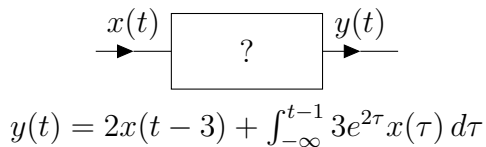

(a) System a

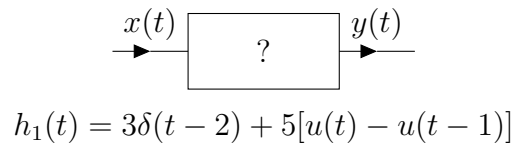

(b) System b

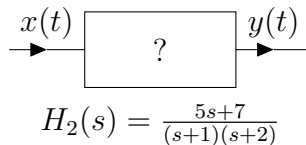

(c) System c

Figure 2: Systems to be built

Problem 2 (10 points) You are given the signals $x_1(t) = u(t - 1)$ and $x_2(t) = u(t - 2)$.

- (a) (2 points) Is signal $x_1(t)$ even or odd? What is the “even part” of $x_1(t)$ if we do even-odd decomposition?
- (b) (4 points) Calculate the convolution integral $x_1(t) \star x_2(2t - 3)$.
- (c) (4 points) Calculate the convolution integral $x_1(2t) \star [x_2(-t)e^t]$.

Hint: You can use the formula for the following integration:

$$\int_{t_1}^{t_2} e^{at} dt = \frac{1}{a} e^{at} \Big|_{t_1}^{t_2} = \frac{1}{a} (e^{at_2} - e^{at_1}).$$

Problem 3 (6 points) Consider a causal LTI system. Someone tells you that when the input is $x(t) = 2u(t)$, the output is $y(t) = (t - 2)u(t - 3)$. Can you find the impulse response $h(t)$ of this system, by

- (a) (3 points) First finding the transfer function through Laplace transform and then taking the inverse transform?
- (b) (3 points) *Without using Laplace transform*, but just by using properties of the $\delta(t)$ function or step function?

